

# INSTRUCTIONS FOR USE

Tipper



# CONTENTS

<b>A. INTRODUCTION</b>	<b>4</b>		
1. GENERAL	4		
2. SAFETY AT WORK	4		
3. OBSERVATIONS	4		
<b>B. SAFETY REGULATIONS</b>	<b>4</b>		
1. PREVENTION OF ACCIDENTS AND OVERVIEW OF WARNINGS AND SAFETY MEASURES	4		
1.1. General	4		
2. PERSONAL PROTECTIVE MEASURES	4		
2.1. Footwear	4		
2.2. Clothing	4		
2.3. Goggles	4		
2.4. Gloves	4		
3. PICTOGRAMS	5		
<b>C. GENERAL DESCRIPTION OF THE TIPPER</b>	<b>7</b>		
1. CHASSIS PART	7		
2. TIPPER PART	7		
3. DIFFERENT TYPES OF TIPPER DEPENDING ON INTENDED USE	7		
4. TIPPING SYSTEM	8		
4.1. Description of the system	8		
4.2. Speed and maximum load	8		
4.3. Position of identification plate and trailer identification number	8		
4.4. Identification plate	8		
4.5. Trailer identification number	9		
<b>D. SYSTEM DESCRIPTIONS</b>	<b>10</b>		
1. KINGPIN, FIFTH WHEEL RUBBING PLATE AND FIFTH WHEEL	10		
2. LANDING LEGS	10		
2.1. Description	10		
2.2. Operation steel type landing leg	11		
2.3. Operation aluminium type landing leg (with one and with two supporting legs)	11		
3. BRAKES	12		
3.1. General	12		
3.2. EBS	12		
3.3. Brake connection	16		
3.4. Prevention of premature brake wear	17		
3.5. Brake synchronisation	17		
3.6. Brake plate	17		
3.7. Drum brake	17		
3.8. Disc brake	17		
3.9. Parking brake – spring brake cylinders	18		
3.10. Emergency brake	18		
4. SUSPENSION	19		
4.1. General	19		
4.2. Raising and lowering valve	19		
4.3. SMARTBOARD	20		
4.4. Load indication through SmartBoard and any possibly calibration	21		
5. WHEEL ACCESSORIES	21		
5.1. Tyres and rims	21		
5.2. Tire Pressure Monitoring	21		
5.3. Spare wheel and spare wheel carrier	22		
5.4. Wheel chock	23		
5.5. Mud guards and mud flaps	23		
6. DOORS	23		
6.1. Barn door	23		
6.2. Top hinged door	24		
6.3. Universal door	25		
6.4. Leakproof rear door	25		
6.5. Hydraulic top hinged door	26		
7. ROOF COVERING			28
7.1. Catwalk with ladders			28
7.2. Roll-over roof sheeting system			28
7.3. Roof sheeting system, type “Dawnbarn”			29
7.4. Roof sheeting system, type “Cramaro”			30
8. TIPPER ACCESSORIES			31
8.1. Towing hook			31
8.2. Grain hatch			31
8.3. Bodyguard			32
8.4. Hinged rear under-run bar			33
8.5. Weighing equipment			33
8.6. Landing legs at the back			34
8.7. Fire extinguisher			34
8.8. Floor heating			34
9. LIGHTING AND SIGNALISATION			35
10. VARIOUS ACCESSORIES			36
10.1. Tool box			36
10.2. Retractable ladder for accessing load space			36
10.3. Side guards			36
10.4. Ladder			37
<b>E. SPECIFIC PROCEDURES</b>			<b>38</b>
1. TRAILER COUPLING AND UNCOUPLING			38
1.1. Coupling			38
1.2. Uncoupling			38
2. TRAILER LOADING AND UNLOADING			38
2.1. General safety instructions concerning loading and unloading			38
2.2. Loading the trailer			39
2.3. Unloading the trailer			40
2.4. Weights and tipping angles for various products			42
3. VENTING THE HYDRAULIC CYLINDER			42
3.1. Hydraulic cylinder of the make HYVA			42
3.2. Hydraulic cylinder of the make EDBRO			42
<b>F. PREVENTIVE MAINTENANCE</b>			<b>43</b>
1. MECHANICAL MAINTENANCE			43
1.1. Visual checks			43
1.2. Tyres			43
1.3. Tightening torques for bolts			43
2. MAINTENANCE SCHEDULE TRAILER BODYWORK			44
3. MAINTENANCE SCHEDULE TIPPING MECHANISM			44
4. MAINTENANCE SCHEDULE ROOF SHEET, TYPE “CRAMARO”			44
5. MAINTENANCE SCHEDULE HINGED REAR UNDER-RUN BAR (OPTION)			44
6. LUBRICATION POINTS			45
7. WHEELS			45
<b>G. TROUBLESHOOTING</b>			<b>46</b>
1. MOST COMMON CAUSES OF PROBLEMS WITH THE TIPPING CYLINDER			46
2. MOST COMMON CAUSES OF PROBLEM WITH THE ROOF SHEET, TYPE “CRAMARO”			46
3. MOST COMMON CAUSES OF PROBLEMS WITH THE “BODYGUARD”			46
4. WABCO DIAGNOSES			47
4.1. Through SmartBoard			47
4.2. Via Interface and PC with voltage supply ISO7638			48
<b>H. TECHNICAL SPECIFICATIONS</b>			<b>49</b>
1. TRAILER - MECHANICAL			49
1.1. Kingpin and fifth wheel rubbing plate			49
1.2. Aluminium landing legs			49
1.3. Landing legs “steel type” (at the front and at the back)			49
2. TIPPING SYSTEM			49
<b>I. COMMENTS</b>			<b>50</b>

## A. INTRODUCTION

### 1. GENERAL

We would like to congratulate you on the purchase of your new STAS trailer.

STAS trailers have been built to serve the user for many years. If the trailer is used and maintained in accordance with the legal provisions and professional regulations, we can guarantee you many years of reliable operation.

We recommend you study the instructions and accompanying documentation carefully prior to using the trailer in order to familiarise yourself with all functions of the trailer and to enable you to use it in the best possible manner. Your trailer has been designed in accordance with current safety standards.

We wish you every enjoyment in the use of your new trailer.

The STAS team.

An up-to-date list of STAS sales points and recognised service points can be found on our website: [www.stas.be](http://www.stas.be).

### 2. SAFETY AT WORK

This manual and accompanying documentation have been drawn up with the following in mind: prevention is better than cure. We would therefore ask you to take note of the following.



**You will have been made aware of the main operational and safety instructions for your trailer at the time of delivery. Please apply them correctly.**

**Please study these instructions and accompanying documentation carefully prior to including the trailer in your trailer fleet.**

**Please ensure the driver of this trailer is also familiar with these instructions.**

### 3. OBSERVATIONS

Although every care has been taken during the compilation and verification of this manual, it may be possible that, as a result of technical progress, certain components vary slightly from the illustrations in the text. STAS nv reserves the right to apply modifications without prior notice and cannot be held liable for any possible errors.

These instructions apply to trailers with a number of different options. It is possible that certain options have not been fitted to your trailer, or are not available for your type of trailer.

This manual should always be kept with the trailer and the operator must be able to refer to it at any time. This manual was originally written in Dutch. It is therefore possible that you are in possession of a translation. The original Dutch manual is also available on request.

Please do not throw this document on the public road.



**The following information is important and should be taken into account when referring to the manual:**

- **The "front" is the front side of the trailer closest to the lorry.**
- **The "back" is the rear of the trailer furthest from the lorry.**
- **In order to determine the left and right hand side, the operator should be looking from the rear to the front of the trailer.**

## B. SAFETY REGULATIONS

### 1. PREVENTION OF ACCIDENTS AND OVERVIEW OF WARNINGS AND SAFETY MEASURES

#### 1.1. GENERAL

As STAS nv is not aware of the conditions in which the trailer will be used, the company cannot assess risks caused by external factors. The owner of the trailer must himself have a risk analysis carried out of such external risks in the interests of his employees and all third parties involved. On the basis of this risk analysis the owner of the trailer is advised to himself provide training for all users of the trailer.

It is strongly recommended that operators who are new to the trailer and tipping system learn to use it with the trailer in an unloaded state.

Any possible information regarding regulations relating to unloading yards, safety procedures, etc. required by drivers who are not employed by the company where the unloading is taking place should always be obtained.

Always inform the person in charge of your arrival and your departure, and comply with the driving and unloading procedures in the unloading yard and the general instructions on site.

Never reverse your trailer without first ensuring it is safe to do so. Ensure there is no one in the danger zone around the trailer. If there is a signalling person present in the unloading yard, ensure that both parties are familiar with the sign being used. Cease any movement if you can no longer see the signalling person.

### 2. PERSONAL PROTECTIVE MEASURES

#### 2.1. FOOTWEAR

When operating the tipper protective footwear should be worn at all times. Footwear may include fixed, high fitting shoes with steel toe caps and insulating soles. Slippers, loose fitting shoes, or shoes which could endanger the operator or which do not offer sufficient protection should never be worn.

#### 2.2. CLOTHING

Suitable clothing should ensure the operator is visible whilst carrying out his work and this will contribute to general safety. Clothing should never be left loose and must always be done up. It should preferably be of an eye-catching colour and be fluorescent which will also offer additional visual safety.

#### 2.3. GOGGLES

Load particles of the cargo may fly around during loading and/or unloading of the tipper. Therefore, the operator of the tipper must always wear approved safety goggles, from the moment he leaves the tipper till he returns to cabin.

#### 2.4. GLOVES

The operator of the trailer should always wear safety gloves in order to avoid injuries caused by sharp or protruding components. Gloves may also offer protection against injuries caused by the nature and characteristics of the load.













**This manual contains some photographs in which the operator is not wearing safety gloves. These photographs were taken deliberately that way, and only for the clarity of the photograph.**

## B. SAFETY REGULATIONS

### 3. PICTOGRAMS

Some of the pictograms listed below can be found on the trailer and/or on the following pages of this user manual. The following is an overview of the warnings and safety measures applicable to your trailer.

	<p>This pictogram appears in various places in this manual and indicates measures which should be observed in order to guarantee safety.</p> <p>This manual should therefore be studied carefully prior to attempting to use the trailer. If particular chapters or paragraphs are unclear, please do not hesitate to contact STAS nv! You should also ensure that everyone who is authorised by you to use the trailer is familiar with and understands these instructions.</p> <p>The self-locking system is a machine as described in the Machinery Directive. The tipping mechanism satisfies the fundamental health and safety requirements as determined in machinery directive 2006/42/EEC.</p> <p>The tipping mechanism may only be used when the trailer is coupled to the lorry.</p>
	This CE marking confirms conformity with the machinery directive.
	This pictogram indicates areas which could present a hazard for fingers and/or other parts of the body. The hazardous areas themselves are indicated by shaded lines.
	This pictogram indicates areas where fingers and/or other parts of the body are at risk of being cut. The hazardous areas themselves are indicated by shaded lines.
	This pictogram indicates the boundary of an area which is not accessible during normal operation.
	This pictogram indicates the outermost moving part of the trailer, and is also used to indicate the hazardous areas where trapping of hands and/or other parts of the body could occur.
	<p>This pictogram indicates the presence of electrical voltage. The trailer receives 24V DC from the towing vehicle.</p> <p>Damaged electrical conductors should be replaced or repaired immediately as they could cause short-circuiting, physical injuries or fire.</p> <p>The components of the electrical system have been carefully balanced. The electrical system for your trailer therefore conforms to the EMC directive.</p>
	This pictogram can be found near electrical connections. It serves to remind the operator that it is not allowed to disconnect the electrical connections by pulling the cable.
	<p>This pictogram can be found near the trailer doors. It serves to remind the operator to ensure there is no one in the immediate vicinity when the doors are opened or closed. In this way, any trapping hazards can be avoided.</p> <p>Danger of trapping also occurs if activities take place between the tipping body and chassis. The tipping body must first be supported by a support suitable for this purpose.</p>
	This pictogram indicates that wearing gloves is strongly recommended.

	This pictogram indicates that wearing safety goggles is strongly recommended.
	This pictogram indicates that wearing safety boots is strongly recommended.
	This pictogram indicates that wearing a safety helmet is strongly recommended.
	This pictogram indicates that the person on the catwalk should protect himself by wearing a safety harness.
	This pictogram indicates the danger of falling objects when opening the roof sheet. Make sure there are no loose parts on the catwalk. These parts can fall downwards during tipping.
	<p>This pictogram indicates the date on which the trailer was painted. This date is important as the trailer should not be cleaned with a high-pressure hose until 4 weeks after it was first painted.</p> <p>During cleaning: the maximum water temperature should be no more than 65°C, only neutral cleaning substances should be used.</p>
	This pictogram indicates a slippery surface as a result of spilt oil.
	The hydraulic cylinder is moved by forcing oil into the cylinder body. When coupling or uncoupling these systems, oil may be spilt. Spilt oil should be removed immediately as it is harmful to the environment and can cause a slipping hazard.
	<p>This pictogram warns of the dangers of obstacles (branches, building constructions, piping, etc.) in the working area of the tipper.</p> <p>Take care when unloading in the vicinity of electrical wires and cables so these are not touched when unloading or driving past.</p> <p>High-voltage lines in the open air can already cause a voltage flashover when the tipping body is still quite a distance from the lines! Voltage flashovers on the vehicle can cause serious burns and electrocution!</p>
	This pictogram warns of the dangers of too high wind speeds. The tipping body may not be tipped with wind speeds higher than 60 kph and in gusts. The force the wind can exert on the side of the tipping body can cause the vehicle to become unstable, with the toppling of the vehicle as a consequence!
See Figure 3.a.	<p>This pictogram (see Figure 3.a.) refers to safety measures to be complied with when tipping. The tipping body of your vehicle is a moving part. Always make sure that there is no one in the immediate vicinity when you move the tipping body.</p> <p>Make sure that no one can become trapped between the tipping body and the chassis when lowering the tipping body.</p> <p>With an automatically opening tailboard it is possible that the board starts moving unexpectedly for a bystander. Always make sure that there is no one in the unloading zone when you start unloading!</p> <p>Also see Specific procedures – § E2 – Trailer loading and unloading.</p>
	<p>As manufacturers of trailers, we would like to improve lorry safety through optimum distribution of the brake force between the lorry and the trailer.</p> <p>We therefore recommend that BRAKE SYNCHRONISATION is carried out between the first 2,000 and 10,000 km each time the lorry is changed in order to achieve the best possible brake force distribution and pattern of wear. Please contact the lorry manufacturer for brake synchronisation.</p>

## B. SAFETY REGULATIONS

### SAFE TIPPING

This cylinder is designed as a lifting device only. It must not be used as a structural member or be a subject to side loads and/or abnormal conditions.  
For optimum use of the cylinder and for safety while tipping, following guidelines should be followed.

Oilspecification : ISO VG with viscosity between 75mm<sup>2</sup>/sec. and 16mm<sup>2</sup>/sec.  
Recommended filtration : 25 µm  
Provide the system with a pressure relief valve set to the maximum working pressure as indicated on the identification shield.

















RIGHT	WRONG
	 <small>OVERLOAD</small>
	 <small>UNEVEN LOADING</small>
	 <small>TIP ON UNEVEN GROUND</small>
	 <small>STAY UNDER AN UNSUPPORTED BODY</small>
	 <small>STAY WITHIN THE WORKING AREA OF THIS MACHINE</small>
	 <small>DRIVE WITH RAISED BODY</small>
	 <small>TIP WITH THE TRAILER IN AN ANGLE TO THE TRUCK</small>

Figure 3.a. – Sticker for safety instructions during tipping



Some pictograms serve as a reminder in order to guarantee correct use of the trailer. There are pictograms containing information on:

- tyre pressure,
- tightening torques for wheel nuts,
- the maximum hydraulic system pressure,
- trailer loading and unloading instructions,
- maximum total weight of tools in tool box,
- tightening bolts and nuts and verification of tracking after the first trip of 300 km maximum,
- identification of connections.
- Carrying out maintenance work on the trailer.

## C. GENERAL DESCRIPTION OF THE TIPPER

The tipper consists of:

- a chassis part
- a tipper part

### 1. CHASSIS PART

The chassis consists of an aluminium or an steel frame. The following parts are assembled on the frame:

- Air suspension with air bags (mechanical suspension is an option not covered in this manual).
- Axles with associated braking system
- Landing legs and wheel accessories
- Lighting and signalisation
- Reinforced construction at the front for end plate with kingpin and fifth wheel rubbing plate to ensure the coupling with the lorry.



The trailer is mounted on 9 ton or 10 ton axles as a low maintenance concept. All axles are fitted with a brake in accordance with the 71/320/EEC and UN/ECE-R13 regulation. The choice of brand for the axles depends on the country or the client. The axles should always be fitted with universal wheel bolts, universal wheel nuts and wheel hub centring.

The air suspension will be of the same manufacturer/make as the axles.

### 2. TIPPER PART

The tipper part consists of a

- tipping body,
- front cylinder (multi-stage single-acting cylinder),
- rear pin hinges

The tipping body has a certain shape depending on the intended use.

The tipping body is provided with door(s) at the back. The different possible types are described in § D.6 – Doors.

Roofing is provided on top of the tipping body. The different possible types are described in § D.7 – Roof covering.



The different types of tipping body, doors and roofing can be combined with each other.

### 3. DIFFERENT TYPES OF TIPPER DEPENDING ON INTENDED USE

The tipper is designed for use as specified at the time of its purchase. Although most tippers have a similar appearance, there may be differences depending on the intended use (e.g. in thickness of the floor and side plates).



Always check that the tipper is suitable for the load to be transported. This means the type of load, the density of the load (also see § E2.4 – Weights and tipping angles for various products), and the suitability of the rear doors for unloading the load. Also remember that the tipping angle can vary depending on the load.

In the case of doubt do not hesitate to contact STAS nv.



## long-term pleasure

### SPECIALIST IN MOVING FLOOR TRAILERS - TIPPERS



buildSTAR  
ALU



ferroSTAR  
STEEL



agroSTAR  
ALU



buildSTAR X  
ALU



ecoSTAR  
ALU



bioSTAR  
ALU



rockSTAR  
STEEL



scrapSTAR  
STEEL



farmSTAR  
ALU



U-rockSTAR  
STEEL



## DISCOVER OUR SPECIALISED OPTIONS ON [WWW.STAS.BE](http://WWW.STAS.BE)

## C. GENERAL DESCRIPTION OF THE TIPPER

### 4. TIPPING SYSTEM

#### 4.1. DESCRIPTION OF THE SYSTEM



**The tipping body of your trailer together with the front cylinder and the rear pin hinges make up a machine.**

**The tipping construction is designed according to the prevailing rules of the machinery directive, directive 89/392/EEC, amended by directives 91/368/EEC, 93/44/EEC and 93/68/EEC and 98/37/EEC and 2006/42/EEC of the Council;**

The single-acting cylinder mounted at the front ensures the raising and lowering of the tipping body.

Control of the cylinder is done by the hydraulic system that is assembled on the towing vehicle or a hydraulic set mounted on the trailer.

A single-line system is used as standard. Here there is one pipe between the hydraulic set (on lorry or on trailer) and the single-acting cylinder. With a single-line system between the lorry and trailer the hydraulic set on the lorry must be protected against overpressure. With a single-line system between a separate hydraulic set on a trailer and single-acting cylinder there is overpressure protection in the hydraulic set.

With a two-line system there is a separate pressure and return oil pipe. A pressure relief valve is fitted on the trailer that is connected to the return pipe. The pressure relief valve protects the cylinder from overpressure.

Two standard makes of hydraulic cylinders are used: HYVA and Edbro.

The pressure of the hydraulic pump that operates the cylinder must be adapted to the maximum permitted cylinder pressure. This maximum permitted pressure is mentioned on the type plate of the cylinder and also on a separate pictogram near the hydraulic connections to the cylinder.



Figure 4.1.a. – Cylinder type plate + maximum cylinder pressure pictogram

#### 4.2. SPEED AND MAXIMUM LOAD

The time required to tip is determined by the speed of the cylinder. The speed depends on the oil flow to the cylinder (with tipping) and the oil flow from the cylinder to the reservoir (with lowering).

The hydraulic pump determines both the oil flow and the maximum oil pressure, and therefore both the tipping time and the maximum permissible load.



**To tip faster the oil flow must be increased. The oil pressure has no influence on the time needed for tipping.**

**The system pressure is determined by the weight of the load, and not by the position of the pressure relief valve or the pump.**

#### 4.3. POSITION OF IDENTIFICATION PLATE AND TRAILER IDENTIFICATION NUMBER

For trailers with symmetrically assembled axles (see Figure 5.1.a.), for semi-trailers with not symmetrically assembled axles (see Figure 5.1.b):

A: The identification plate is fixed either to the right in the vicinity of the vehicle identification number or on the first beam of the chassis on the right-hand side.

B: The trailer identification number is stamped in the chassis to the right at the bottom

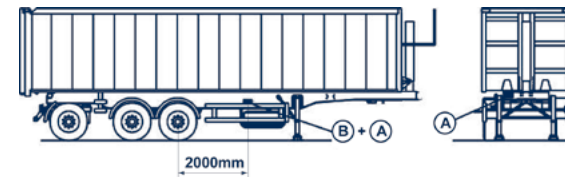

Figure 4.1.a. – Position identification information with symmetrically assembled axles

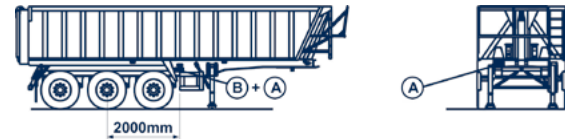

Figure 4.1.b. – Position identification information trailers with not symmetrically assembled axles

#### 4.4. IDENTIFICATION PLATE

The plate mentions (see Figure 4.2.a.):

N.V. STAS		STAS		CE	
e6*2007/46*0003*03		52115		S300CX	
YE6S300CX90000014		C1B		F21A	
(DE)		2040		2009	
36000 KG		39000 KG		MS33439L5EBS	
0:	12000 KG	12000 KG	14040	2550	12000
1:	8000 KG	9000 KG	27000	12000	12000
2:	8000 KG	9000 KG			
3:	8000 KG	9000 KG			
4:					
T:	24000 KG	27000 KG			

Figure 4.2.a. – Identification plate

- Manufacturer's name (1).
- EEC authorisation number (2).
- Trailer identification number (3).
- Legally permissible maximum load of the trailer (4a).
- Technically permissible maximum load of the trailer (4b).
- Legally permissible maximum load for each of the axles (from front to back) (5a).
- Technically permissible maximum load for each of the axles (from front to back) (5b).



## C. GENERAL DESCRIPTION OF THE TIPPER

---

- Legally permissible maximum load on the fifth wheel (6a).
- Technically permissible maximum load on the fifth wheel (6b).
- Number national type approval (7).
- Trailer type (8).
- Variant of trailer (9a).
- Version of trailer (9b).
- Year of manufacture (10).
- Brake schedule reference (11).
- Reference number (internal order number) (12)
- Product type (13)
- The RT value (only applicable for certain export markets).
- Swing radius (KS).
- Length (L) of trailer.
- Width (W) of trailer.
- a.min and a.max: the minimum and maximum distance between the front of the towing vehicle and the coupling device.
- b.min and b.max: the minimum and maximum distance between the coupling device and the rear of the trailer.
- Country of registration



**When determining the weight, an evenly distributed load in the trailer is assumed.**

### 4.5. TRAILER IDENTIFICATION NUMBER

The trailer identification number consists of a combination of 17 characters. For the correct position, see § 4.1.



Figure 4.3.a. - Trailer identification number

## D. SYSTEM DESCRIPTIONS

### 1. KINGPIN, FIFTH WHEEL RUBBING PLATE AND FIFTH WHEEL



Figure 1.a. – Fifth wheel rubbing plate with kingpin

In order to achieve a good and safe driving style for the lorry/trailer combination it is essential to respect the correct coupling height. The guiding value for the coupling height is stated on the sticker which is attached to the trailer.

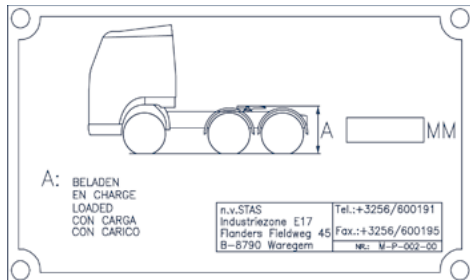

Figure 1.b. – Sticker coupling height for 3-axle lorry

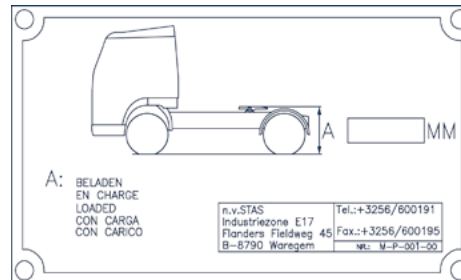

Figure 1.c. – Sticker coupling height for 2-axle lorry



If the coupling height is not respected, STAS nv cannot be held liable for any harmful consequences. Please contact STAS nv for information on setting the coupling height for your lorry/trailer combination or for further information.

The trailer is manufactured in conformity with ISO 1726-1973 (Road vehicles mechanical connections between lorries and trailers, exchangeability). This concerns the swing radius between lorry and trailer.

On first bringing into use it must always be verified that there is no interference between lorry and trailer (e.g. when turning).

### 2. LANDING LEGS

#### 2.1. DESCRIPTION

Landing legs serve to support the trailer when it has been uncoupled.

There are two versions, being the “steel type”, the “aluminium type”. The “steel type” is fitted with a handle for adjusting the height of the landing leg and is therefore also used for adjusting the correct coupling height for the trailer when coupling the trailer to a lorry.



Figure 2.1.a. – “Steel type” (left) and (right) “aluminium type with two landing legs”

All versions of landing legs are fitted with a rolling base which is able to absorb limited forward movement (as a result of loss of pressure in the air bags) provided the trailer is parked on a hard surface.



Uncoupling and parking the trailer should be done on a solid and flat surface. Provided the trailer is fitted with a rolling base, it is NOT necessary to bleed the air suspension prior to uncoupling.



The trailer must be equipped with air suspension in order to be able to use the “aluminium type” landing leg.



The aluminium type with one landing leg may only be used to support an EMPTY TRAILER.

## D. SYSTEM DESCRIPTIONS

### 2.2. OPERATION STEEL TYPE LANDING LEG

#### Uncoupling the trailer

Proceed as follows:

- Release the handle.



Figure 2.2.1.a. – Storage space landing leg handle "steel type"

- Pull the handle out completely in order to select high speed.



Figure 2.2.1.b. – Landing leg handle "steel type" pulled out

- Turn the handle clockwise until the landing legs touch the ground.



Figure 2.2.1.c. – Landing leg handle "steel type"

- Select low speed by pushing the handle inwards.
- Turn the handle until the trailer is fully supported.
- Return the handle to its storage position (in the clip).
- The landing legs are now in the correct position for the trailer to be uncoupled.

#### Coupling the trailer

Proceed as follows:

- Release the handle.
- Select low speed by pushing the handle inwards.
- Turn the handle until the position of the fifth wheel rubbing plate is just below the fifth wheel of the lorry.
- The landing legs are now in the correct position for the trailer to be coupled.
- Do not forget to return the landing legs to their highest position once the trailer has been coupled.

### 2.3. OPERATION ALUMINIUM TYPE LANDING LEG (WITH ONE AND WITH TWO SUPPORTING LEGS)

#### Uncoupling the trailer



**The aluminium type with one landing leg may only be used to support an EMPTY TRAILER.**

Proceed as follows:

- Ensure the air suspension of the lorry is in the "driving position", pull out the locking pin of the landing leg and hold the leg by the handle on the base. Move the first landing leg down until this touches the ground.



**Do not allow the landing leg to fall, but guide it by hand in order to avoid damaging it.**

- Repeat the above for the other supporting leg (type with 2 supporting legs).



Figure 2.3.1.a. – "Aluminium type" landing leg

- Secure the locking pins for both landing legs into the lowest possible hole.



**Both landing legs must be lowered to the same length in order to distribute the load of the trailer evenly.**  
**Ensure the locking pins are always securely in position.**

- If, after the landing leg has been secured with the locking pin, there is a 1 to 2 cm gap between the base and the ground (depending upon the position of the holes), use the air suspension of the lorry to gently lower the trailer until the landing legs make contact with the ground and are able to take the load of the trailer. The landing legs are now in the correct position for the trailer to be uncoupled.



**We strongly advise you not to leave the trailer uncoupled from the lorry in a loaded condition for several days because the weight on the landing legs will become unbalanced as the air slowly flows out of the air suspension.**

## D. SYSTEM DESCRIPTIONS

### Coupling the trailer

As the height of the “aluminium type” landing legs is not adjustable, adjustment takes place using the air suspension of the lorry.

Once coupling has been carried out, proceed as follows:

- Pull the locking pin out of the first landing leg and position the landing leg as high as possible using the lever on the base of the landing leg.
- Position the locking pin in order to secure the landing leg in the highest position.
- Pull the locking pin out of the other landing leg (with the type with 2 supporting legs), also position this as high as possible using the lever on the base of the landing leg and reposition the locking pin.



Ensure the locking pins are always positioned securely and cannot be released.

## 3. BRAKES

### 3.1. GENERAL

Modern lorries and trailers are expected to be safe, efficient, comfortable and environmentally friendly. An important step for complying with these requirements is the introduction of an electronically controlled braking system for trailers or EBS (Electronic Brake System).

EBS allows the continuing best possible synchronisation of the brake forces between the various wheel brakes and between the lorry and its trailer.

The tipper trailer is provided as standard with the WABCO trailer EBS-E system on air suspension axles. Mechanical suspension is an option not covered in this manual.

The electronically controlled braking system is equipped as standard with load sensing brake force adjustment and anti-locking system (ABS).

The EBS system:

- complies with the legal requirements,
- conforms with directive 71/320/EC,
- conforms with directive UN/ECE-R13,
- complies with the requirements applicable to trailers suitable for transporting hazardous substances.



Only WABCO recognised maintenance centres have the appropriate software for maintaining the braking system and setting the parameters.



For correct maintenance of the brakes or in case of problems with the brakes:

- consult the Internet site [www.wabco-auto.com](http://www.wabco-auto.com), then click on : “Find WABCO Service Locations” , choose your country and make a choice between Service Center and/or Service Point and/or Dealer and/of WABCO and press “Start search”. The requested details will be listed.
- contact STAS nv factories, a recognised representative or dealer appointed by STAS nv or a STAS nv designated service point.

### 3.2. EBS

#### System layout

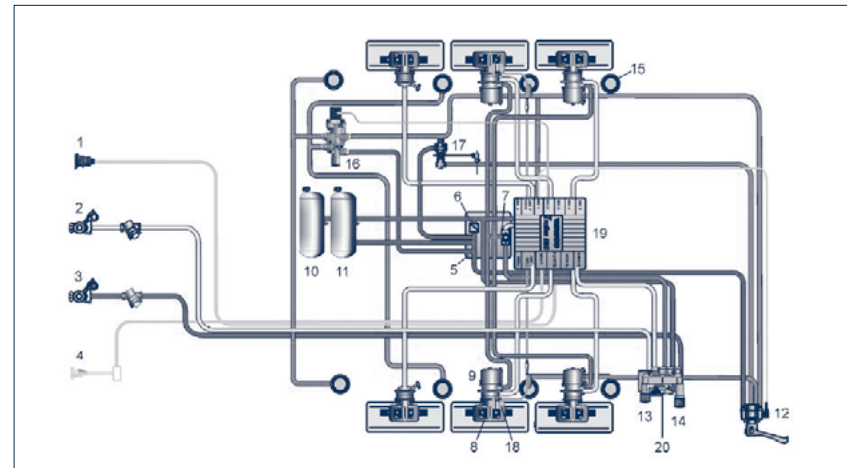

Figure 3.2.1.a. – Example EBS system layout 2S/2M

- |   |  |
|---|--|
| 1. Voltage supply via ISO7638                         | 11. Reservoir for air suspension                   |
| 2. Control line                                       | 12. Lifting/Lowering valve                         |
| 3. Supply line  | 13. Red button for actuating the parking brake     |
| 4. Stop light supply via ISO1185 (optional)           | 14. Black button for releasing the automatic brake |
| 5. Pneumatic Extension Module (PEM)                   | 15. Supporting Bellows                             |
| 6. Charging valve (integrated in the PEM)             | 16. Lifting axle valve                             |
| 7. Overload protection valve (integrated in the PEM)  | 17. Levelling valve                                |
| 8. Service brake components of the Tristop® cylinders | 18. ABS rotational speed sensors                   |
| 9. Tristop® cylinder                                  | 19. Trailer EBS E Modulator                        |
| 10. Reservoirs of the service brake system            | 20. Parking release emergency valve (PREV)         |

Depending upon the number of wheel speed sensors (S) and control loops (M), this configuration is described as 2S/2M or 4S/2M.

Extension of the 4S/2M configuration with an EBS relay valve for pressure adjustment of the third axle for trailers is described as 4S/3M.

#### System description

##### Electro-pneumatic function

The Trailer EBS system is electrically switched on by pin 2 of the socket connection to ISO7638.

If the electrical supply to the ISO 7638 plug connection fails, the braking system can be regulated by an optional brake light facility. Immediately after the Trailer EBS has been switched on, a system check is performed. Two seconds after start-up, the magnets in the trailer modulator will be attracted or connected one by one. This procedure can be heard by the magnets clicking. The system is ready for operation within 150 ms of being switched on.



Once the Trailer EBS has been switched on, limited ABS functionality may be available, because a dynamic check of the ABS sensors will only be carried out once the trailer has driven off for the first time.

## D. SYSTEM DESCRIPTIONS

For electro-pneumatic control, the integrated redundancy valve is activated at the start of the braking action, resulting in the pneumatic command pressure being removed and air tank pressure being applied at the front of the inlet valves of the modulators. This will enable the brake cylinder pressure to be regulated up to air tank pressure.

For pressure regulation, the current setting is transmitted to the trailer modulator and is then regulated depending upon the load. In order to adapt the brake forces to the various loads, the bags pressure which is sent to the trailer modulator through a pneumatic pipe is measured.

The required deceleration is preferably electronically determined via the CAN data bus connection with the towing vehicle. If this connection is not available, the required value is determined using the integrated pressure sensor in the trailer modulator.

Brake pressure regulation is realised by control circuits with pulse controlled relay valves. For the adjustment of the brake forces to the load on trailers with air suspension, the air bags pressure is measured by a pressure sensor.

### Pneumatic redundancy

In case of faults in the EBS-system resulting in a partial disconnection, the pneumatic command pressure will go to the open inlet valve and the closed outlet valve, so that brake pressure is controlled purely pneumatically, but without load-sensing control. The ABS control will remain operative for as long as possible. The driver is alerted by a warning light on the dashboard when a fault is detected.

### Electric/electronic system layout

During normal use the trailer modulator is electrically powered by two wires from the ISO7638 which are each fitted with a fuse.

For safety purposes, the electrical supply may be regulated via the brake light in order to maintain some regulatory functions if the electrical supply through ISO7638 should fail.

The data bus connection between the towing vehicle and the trailer modulator is made via ISO11992. The details are checked and processed by the trailer modulator.

If the trailer has been coupled to a towing vehicle without EBS, a pressure sensor for determining the required brake value is integrated in the trailer modulator. The required value is checked for plausibility. Pneumatic redundancy is achieved by the 3/2 magnet valves integrated in the trailer modulator. At the start of each braking cycle, the trailer modulator energises the magnet valves and removes the redundancy.

The brake pressure of the third axle with a 4S/3M-configuration is controlled with an electro-pneumatic EBS-relay valve. A brake pressure sensor and a 3/2 magnet valve have been integrated into this valve. The brake pressure sensor is powered by the trailer modulator. The actual value is transmitted as an analogue signal. In order to protect all active sensors from short-circuiting, they are connected to the trailer modulator.

A pressure sensor for monitoring the supply pressure as well as two pressure sensors for the actual brake pressure have been integrated in the trailer modulator and are powered by the trailer modulator. The actual values are transmitted as analogue signals.

For the determination of the suspension pressure, a pressure sensor has been integrated in the trailer modulator, and a pneumatic pipe is led from the trailer modulator to the bags.

For controlling wear on the brake pads, they have been fitted with indicators for the end value, the signals of which are monitored by the trailer modulator and transmitted to the towing vehicle.

System faults are recognised by the trailer modulator and stored in accordance with a fixed fault matrix in the diagnostic memory.

The trailer modulator has the following connections:

### A - Pneumatic connection:

TEBS E Modulator with PEM	
	<ul style="list-style-type: none"> <li>1. Supply (to the reservoir "Brake")</li> <li>1.1 Supply "Air Suspension" (to air suspension valve, rotary slide valve, lifting axle valve or ECAS block)</li> <li>2.1 Braking pressure (to the brake cylinder)</li> <li>2.3 Tristop® cylinder (to the Tristop® cylinder (12))</li> <li>4 Control pressure (to PREV 21)</li> <li>5 Bellows pressure (to air suspension bellows)</li> </ul>
	<ul style="list-style-type: none"> <li>1 Supply (to the reservoir "Brake")</li> <li>2.2 Braking pressure (to the brake cylinder)</li> <li>2.3 Tristop® cylinder (to the Tristop® cylinder (12))</li> <li>4.2 Control pressure (to PREV 22)</li> </ul>
	<ul style="list-style-type: none"> <li>1 Supply (to the reservoir "Brake")</li> <li>2.4 Test connection "Brake"</li> </ul>

Figure 3.2.2.a. – Pneumatic connection

## D. SYSTEM DESCRIPTIONS

### B - Electronic connection

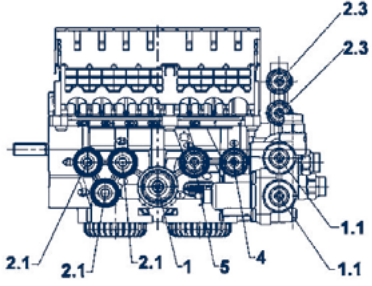
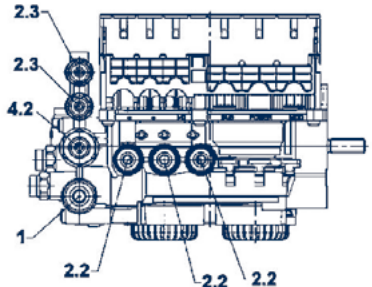
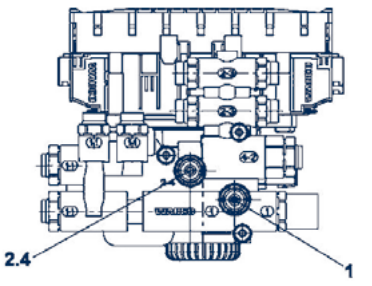
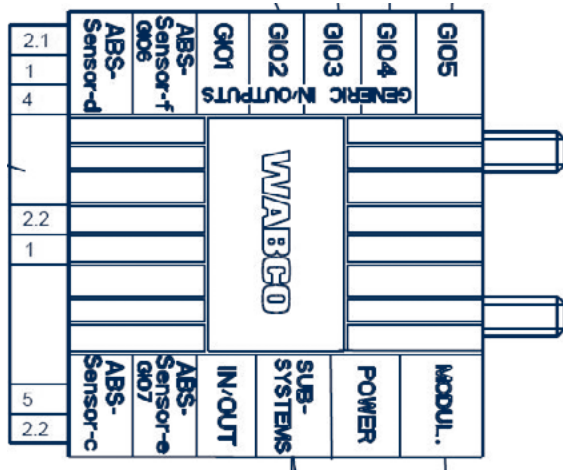

Figure 3.2.2.b - Electronic connection

POWER	Connection ISO 7638 7 pin voltage supply
SUBSYSTEMS	Connection for SmartBoard
MODULATOR	Connection for 3rd modulator (4S/3M or 4S/2M+1M)
IN/OUT	Stop light supply or TCE
ABS - C - D	ABS sensoren main
ABS - E - F	ABS sensoren additional
GIO 1-7	Multifunctional ports IN-OUT

### Roll Stability Support (RSS) (optional)

There are various definitions relating to a vehicle rolling over:

- A vehicle may roll over if the critical lateral acceleration is less than the maximum friction between the tyres and the road.
- The critical lateral acceleration for rolling over is the limit value of the force which is allowed to affect a vehicle laterally in the driving direction before the vehicle rolls over.
- The maximum friction between the tyres and the road is the limit value of the force, which is allowed to affect a vehicle laterally on the driving direction before the vehicle slips.

Trailers often have a relatively high centre of gravity and are therefore extremely likely to roll over when tight bends are being taken at too high speeds. For trailers, the critical lateral acceleration may be lower than that of the lorry. In contrast to the rolling over risk of the lorry, the driver often notices this too late where the trailer is concerned in order to be able to take corrective action (by braking for instance). With the aid of the RSS function, the imminent risk of the trailer rolling over is recognised and corrected by automatic braking. This reduces the risk of rolling over.

The RSS function uses the available details of the Trailer EBS:

- wheel speed,
- information on the load,
- information on the required deceleration,
- information from the sensor for lateral acceleration integrated in the EBS modulator.

RSS recognises the risk of rolling over as a result of strong relief in pressure on the wheels in the inside bend. When the calculated critical lateral acceleration of the trailer is exceeded, a low testing pressure is temporarily applied. Duration and height of the pressure depend upon the current critical lateral acceleration. The risk of rolling over is recognised using the wheel reaction during test braking.

When the risk of rolling over is detected, high pressure braking on the wheels of the trailer in the outside bend will take place in order to prevent rolling over. The brake pressure for the wheels in the inside bend will remain mainly unchanged, depending upon any ABS regulation.



**When braking in accordance with RSS, the brake lights do not illuminate because the brake light can only be activated by the lorry whereas RSS braking is controlled by the trailer.**

RSS adjustment starts during a driving situation with partial or no braking. If the driver brakes sufficiently (retardation above the level of the RSS retardation) RSS is not activated. If, during an RSS adjustment of the trailer which has already started, the lorry indicates a pneumatic or electric braking value, RSS adjustment will be cancelled as soon as the braking value of the lorry is higher than that of the RSS. The braking pressure



**As a result of the RSS control, the physical limits cannot be exceeded. If there is a further increase in lateral forces on the trailer, despite automatic braking and the resulting retardation, and the reduction in lateral acceleration being too slow, the trailer combination may still roll over even if RSS is activated.**

re in the trailer is then adjusted to the requirements of the lorry up to the end of the braking operation. During driving the following are compensated: up to 9% variation in tyre circumference, misalignment of modulator up to 3 degrees on the longitudinal axle of the vehicle plus the offset tolerance of the lateral acceleration sensor. The RSS function may be out of operation or react slowly up to the level of compensation. The warning light may even go out before the RSS is functioning at its best.

When trailers are driving without any pressure in the air bags, it may be that the RSS does not detect any risk of rolling over due to a lack of information on the load.

Once faults are detected, the RSS is permanently switched off and the warning light is activated. In this instance, correct RSS functioning can no longer be guaranteed.

## D. SYSTEM DESCRIPTIONS

### Standstill function

With a vehicle at a standstill (speed < 1.8 kph) and a command pressure greater than 3.5 bar, after 5 sec. switching takes place from electro-pneumatic to pneumatic brake pressure. This function serves to prevent unnecessary use of electricity when the combination is stationary with the handbrake on and the ignition on. This function is deactivated when driving commences.

### Emergency brake function

In order to be able to exert maximum brake force at all times, an emergency brake function has been integrated. If the brake pressure value desired by the driver corresponds to more than 90% of the available supply pressure, a so-called emergency stop, the brake cylinder pressures will be increased up to the supply pressure. This function is also operative when a suspension air bag has burst.

### Verification of supply pressure

The supply pressure to the trailer is verified by the EBS. If the pressure drops below 4.5 bar the driver is alerted by the red and yellow warning lights. Once the pressure of the air pressure braking system has been corrected and the pressure of the trailer exceeds 4.5 bar, the lights will go out. If the supply pressure drops below 4.5 bar during driving, this will be stored as a fault.

### Kilometre indicator

The Trailer EBS is fitted with an integrated kilometre indicator, which measures the distance covered when the EBS system is functioning. Two separate functions are available:

- The total number of kilometres indicates the total amount of kilometres driven since the system was put into operation. This value is saved on a regular basis and can be read with the aid of the various diagnostics equipment or SmartBoard.
- A tripometer is also available. This can be reset to zero at any time. In this way the number of kilometres between two maintenance inspections can be determined or the number of kilometres driven since a particular time. Diagnostic equipment or SmartBoard is used to read and reset the tripometer.

Special calibration is not required. The calibration factor is calculated using the tyre circumference and the number of teeth in the field system, which are entered during the final inspection of the Trailer EBS. The kilometre indicator requires an electrical supply. It will therefore only function when the Trailer EBS is electrically connected and is not tamper-proof.

### Service signal

This function may be activated using diagnostic equipment. If this function has been activated, a warning light can be set to be activated after a certain number of kilometres, selected with the aid of the diagnostic equipment, have been covered. This warning light will illuminate the first time the ignition is switched on after the selected number of kilometres have been covered and will flash eight times. The flashing will repeat itself every time the ignition is switched on and will help to remind the driver the trailer is due for a service, etc.

The service signal may be reset. After resetting, the set service interval as described will be re-activated.

This function is not switched on at the time of delivery.

### Operation hour counter

The elapsed operation time is stored in the memory and may be read via the diagnostic socket or SmartBoard.

The counter for the operational hours only functions when the Trailer EBS is electrically connected and is therefore not tamper-proof.

### ILS (Integrated Load Switch) (optional)

If the trailer is equipped with lift axle(s), these may be automatically controlled independently of the actual axle load by the Trailer EBS. To this end, an electrical axle lift valve should be connected to the GIO plugs of the trailer modulator.

The axle load at which the lift axle is lowered is calculated using the pressure present in the air bags and using the details of the bags pressure and the axle load in laden and unladen conditions which have been set in the parameters.

The vehicle speed at which raising the lift axle(s) can be carried out is between 0 and 30 km/hour. Diagnostic equipment is used to set the parameters.

When a fault is detected in the axle load sensor, the lift axle will be lowered at speeds between 5 and 30 km/hour and will not be activated at a speed below 5 km/hour.

Only ABS sensors e and f may be connected to the lift axle. ABS sensors c and d should always be connected to the main axle.



**During technical inspection and verification, it should be possible to lower the axle when the trailer is unloaded. This may be done by switching off the trailer ignition or through the SmartBoard operation. The axle is then lowered and will remain in this position regardless of the load. The axle will only be raised when the speed of the trailer exceeds 15 km/hour.**

### Lift axle traction help (optional)

A lift axle traction help may be set up on trailers with a first axle as the lift axle or with the first axle with axle deflation (air suspension dump valve). The value for the axle load for the lift axle traction help should be no more than 30% above the maximum permissible axle load and should be determined by the manufacturer. Once a speed of 30 km/hour has been reached, the axle will come back down or the first axle will be inflated.

The TH version (an axle lift valve) means that the lift axle may be lifted or that the air suspension dump valve can be deflated to help driving off, when the permissible bags pressure set in the parameters is not exceeded after lifting. If the permissible pressure is exceeded during driving off, the lift axle traction help is interrupted and the lift axle will come back down or the air suspension dump valve will be inflated.

**Please note: The operation first axle with axle deflation (air suspension dump valve) does not work independently or separately of the lift axle traction help.**

The lift axle traction help (or forced lifting) is being activated:

- either through an impulse button connected to the power supply (+24 V) or minus (0 V) and on a GIO of the modulator (with cable) and if the parameters have been set accordingly. The impulse on the button needs to be between 0,1 and 5 seconds.
- or by pushing 3 times the brake pedal if the parameters have been set accordingly on the GIO of the modulator (without cable).
- or through the SmartBoard if the parameters have been set accordingly.

In order to disconnect the lift axle traction help:

- either when the impulse on the button is more than 5 seconds (with cable).
- or by pushing again 3 times the brake pedal (without cable).
- or through the SmartBoard.

### Wear indicator (optional)

Up to 6 indicators for monitoring wear on the brake pads can be connected to the electronic system. The wear indicators (a wire integrated into the brake pad) measure the wear on both brake pads. All indicators are connected in series and connected to the wear input in a voltage distributor. The driver is alerted via the ABS warning light shortly before and when the limit of wear has been reached.

## D. SYSTEM DESCRIPTIONS

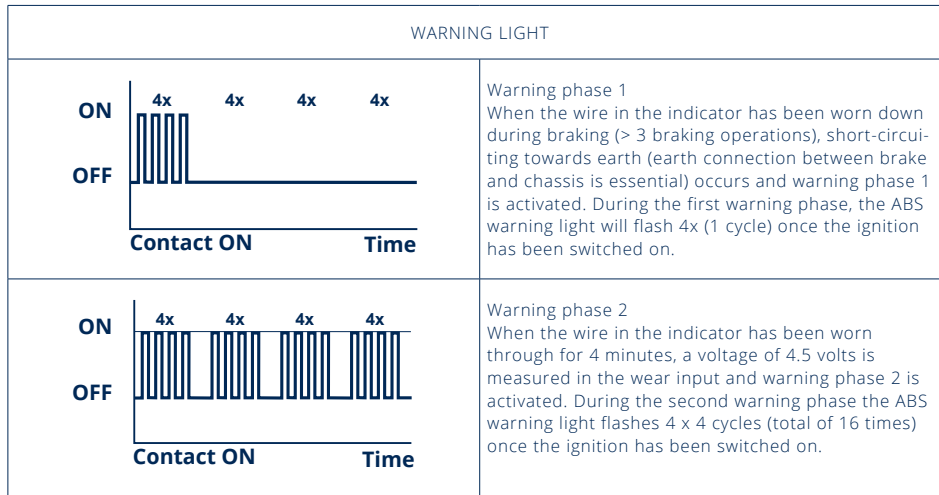

The warning is interrupted when the trailer exceeds a speed of 7 km/hour. In case of system faults, the ABS warning light is permanently activated.

The corresponding information is simultaneously transmitted to the lorry/trailer interface and can be displayed on the display.

The system automatically detects when new wear indicators have been installed after the brake pads have been replaced. All warning lights will be de-activated after approx. 2 minutes (switch on ignition for a minimum of 2 minutes). The warning light will only go out when the ignition is switched on again.

The last five replacements of the brake pads (position of kilometre indicator and operational hours when the second warning phase and replacement of brake pads have taken place) are stored in the ECU and can be read using the PC diagnostics.

### 3.3. BRAKE CONNECTION

The connecting points on the trailer are located at the front. The command line is colour coded yellow and the supply line is colour coded red.



Figure 3.3.a. – Connection braking system



- When uncoupling the connecting hoses, the brakes are automatically activated.
- Once the air pipes have been disconnected, the connecting points should be protected against soiling by water or dust by placing the lids of the connections over the apertures.
- The parking brake is NOT automatically set once the command and supply air pipes have been disconnected.
- Repairs to the brake system may only be carried out by qualified engineers.
- Any components in the brake system which need replacing should always be replaced by original components.



Trailers equipped with the EBS-E brake system may only be coupled to lorries with either:

- an ISO7638-1996 electrical connection (7-pin, 24V, CAN-databus),
- an ISO7638-1985 electrical connection (5-pin, 24V, no CAN-databus).



Figure 3.3.b. – 7-pin socket (left) and 5-pin socket (right)



If the ISO7638 cable is not connected, the ABS and additional functions will NOT be operative. In this case, the brake system will operate as a conventional brake system.



## D. SYSTEM DESCRIPTIONS

### 3.4. PREVENTION OF PREMATURE BRAKE WEAR

See also "Wear indicator (optional)" on page 18.

It may be possible that a lorry/trailer combination does not brake properly. Upon further investigation, it is usually found that in case of a trailer with drum brakes, the brake lining has been glazed or burnt and the brake drums have torn. In case of a trailer with disc brakes, it appears the brake pads have completely worn after a limited number of kilometres and the brake discs show deep grooves.

For articulated vehicles, the lorry as well as the trailer conform with European directives or the regulations of the United Nations. In practice however, it appears that with a combination of these two optimum braking is not performed. Nevertheless, it is most important that each of the vehicles takes its share of the braking force in a correct manner and under any loading conditions.

Synchronisation of the brake system (see § 3.5) on the lorry and the trailer prevents these problems.



Please also refer to the additional documentation supplied with the trailer.

### 3.5. BRAKE SYNCHRONISATION



Between the first 2,000 and 10,000 km and after each change of lorry brake synchronisation is recommended.

This brake synchronisation, which should be carried out by the lorry manufacturer, is recommended in order to obtain optimum brake force distribution and an optimum wear pattern between the lorry and the trailer.

Damage and wear as a result of poor brake synchronisation will not be accepted under warranty under any circumstances. We therefore recommend brake synchronisation is performed and the synchronisation report is kept in a safe place. Always ensure that the report clearly states the details of the lorry and the trailer, including the date on which the synchronisation was performed.



Please also refer to the additional documentation supplied with the trailer.

### 3.6. BRAKE PLATE

As the braking system is fitted with EBS, the brake plate has been replaced by a sticker. The parameters of the EBS controlled brake system can be found on this sticker.



The EBS system may only be checked by a recognised Wabco service point which has the appropriate software.

WABCO		TRAILER EBS-E		DISC BRAKE (TRAILER) 100-1000	
Model	ALUTRAILER	GV0	Pist	Pist	Pist
GV0	S3000X	1	SAC	AVL	...
GV0	YES/NO/ZG/001033	2	SAC	AVL	...
GV0	...	3	0.51	...	...
GV0	...	4	...	TR	...
GV0	...	5	1.08	...	...
GV0	...	6	...	...	...
GV0	...	7	...	...	...
GV0	...	8	...	...	...
GV0	...	9	...	...	...
GV0	...	10	...	...	...
GV0	...	11	...	...	...
GV0	...	12	...	...	...
GV0	...	13	...	...	...
GV0	...	14	...	...	...
GV0	...	15	...	...	...
GV0	...	16	...	...	...
GV0	...	17	...	...	...
GV0	...	18	...	...	...
GV0	...	19	...	...	...
GV0	...	20	...	...	...
GV0	...	21	...	...	...
GV0	...	22	...	...	...
GV0	...	23	...	...	...
GV0	...	24	...	...	...
GV0	...	25	...	...	...
GV0	...	26	...	...	...
GV0	...	27	...	...	...
GV0	...	28	...	...	...
GV0	...	29	...	...	...
GV0	...	30	...	...	...
GV0	...	31	...	...	...
GV0	...	32	...	...	...
GV0	...	33	...	...	...
GV0	...	34	...	...	...
GV0	...	35	...	...	...
GV0	...	36	...	...	...
GV0	...	37	...	...	...
GV0	...	38	...	...	...
GV0	...	39	...	...	...
GV0	...	40	...	...	...
GV0	...	41	...	...	...
GV0	...	42	...	...	...
GV0	...	43	...	...	...
GV0	...	44	...	...	...
GV0	...	45	...	...	...
GV0	...	46	...	...	...
GV0	...	47	...	...	...
GV0	...	48	...	...	...
GV0	...	49	...	...	...
GV0	...	50	...	...	...

Figure 3.6.a. - Sticker EBS braking system

### 3.7. DRUM BRAKE

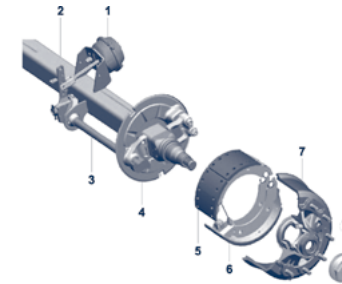

Figure 3.7.a. - Drum brake

The trailer brake operates according to the general drum brake principle. The force of the brake cylinder (1) starts up the brake shaft via brake rods (2, 3) in a rotary movement. The cam (4) at the end of the brake shaft spreads the brake pads (5) and in this way pushes them against the inside of the brake drum (7) resulting in an effective braking force.

When the brake pedal is released, the cylinder pressure on the rods is removed and the brake shaft and cam return to their original position. The brake pads are also returned to their original position by return springs (6). The brake force is removed.

### 3.8. DISC BRAKE

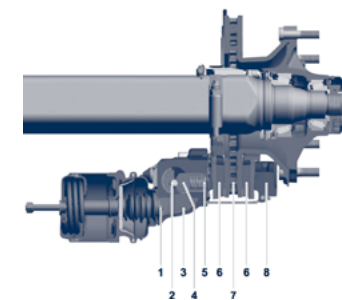

Figure 3.8.a. - Disc brake

When the brake pedal is operated, the connecting rod (1) of the brake cylinder pushes on the lever (2) of the disc brake. The wheel which is eccentrically mounted on bearings (3) transfers the force to the bridge (4). The clamping force impacts upon the inner brake lining via the threaded rod and the piston (5). The brake lining (6) pushes itself off against the brake disc (7). The reactive force which is generated on the brake saddle (8) is transferred to the opposing brake lining resulting in this also being pushed against the brake disc with an equal force and generating an effective braking force.

## D. SYSTEM DESCRIPTIONS

### 3.9. PARKING BRAKE – SPRING BRAKE CYLINDERS

The parking brake with spring brake cylinders operates as follows:

- As the pneumatic pressure in the spring brake cylinder disappears, the spring is released and generates a brake force in this way.
- As the pneumatic pressure builds up in the spring brake cylinder, the force of the spring is removed and the brake force is removed.



Figure 3.9.a. – spring brake cylinders

The control unit for the parking brake is located on the side of the trailer, together with the raising and lowering valve and the loading gauge.

The red control button for the spring brake cylinders can be found on the left hand side of the control unit (see Figure. 3.9.b.).

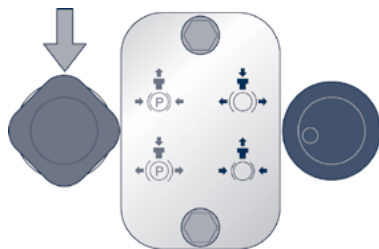

Figure 3.9.b. – Control unit parking brake with control button

Operation of the parking brake can be summarised as follows:

- Pull out the red button to activate the trailer parking brake.
- Push the red button to switch off the trailer parking brake.



- After disengaging the parking brake it is possible that one **CANNOT** immediately drive away. The pressure in the spring brake cylinder needs to rise first before the parking brake is released.
- Ensure the parking brake is sufficiently engaged before leaving the trailer unattended.
- It is advisable to place a wheel chock in front of or behind the wheels for additional protection.
- Always park the trailer on a horizontal and stable surface, **NEVER** on an incline.

### 3.10. EMERGENCY BRAKE

This function is used when the trailer is not connected to the lorry and it is necessary to move the trailer using a fork lift truck for instance.

When the red air pressure pipe between the lorry and the trailer is uncoupled, the brake system on the trailer will automatically go into the braking position so that, in principle, the trailer cannot be moved. With the aid of the emergency brake, the trailer can still be moved without the lorry.

The control unit for the emergency brake is located on the side of the trailer, together with the raising and lowering valve and the loading gauge. The black control button for the service brake is located on the right hand side of the control unit (see Figure 3.10.a.).

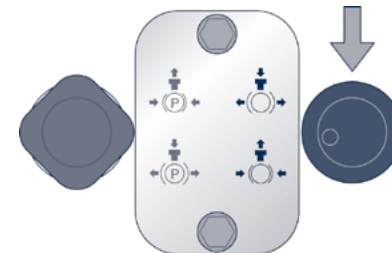

Figure 3.10.a. – Control unit emergency brake with control button

Operation of the emergency brake can be summarised as follows:

- Push the black button to activate the emergency brake in order to move the trailer (using a fork lift truck for instance).
- Pull out the black button to re-activate the service brake for the trailer.

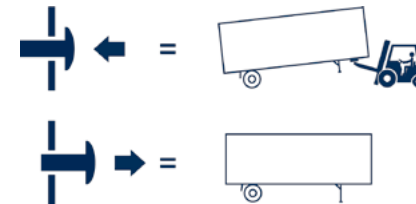

Figure 3.10.b. – Use of the emergency brake



Use of the emergency brake requires a pressure of more than 4 bar in the pneumatic circuit.

## D. SYSTEM DESCRIPTIONS

### 4. SUSPENSION

#### 4.1. GENERAL



Figure 4.1.a. – Air suspension



**The trailer is fitted with air suspension as standard. Mechanical suspension is an option that is not covered in this manual.**

The air suspension of the trailer ensures the chassis of the trailer is spring-mounted with regards to the axles of the trailer and is able to absorb the shocks in this way. The pressure in the air bags is regulated automatically in such a way that for each load, maximum driving comfort and minor movement of the superstructure is obtained. This also results in good road holding and little tyre wear.

#### 4.2. RAISING AND LOWERING VALVE

The valve for raising and lowering on a trailer with air suspension allows the height of the trailer chassis to be adjusted for loading and/or unloading the trailer.

This valve is used to adjust the difference in height between the axles and the chassis of the trailer.



Figure 4.2.a. – Raising and lowering valve

The raising and lowering valve has 5 positions:

- Position for lowering the chassis to its lowest position (lever clockwise in outer position).
- Position for stopping the lowering movement.
- Driving position.
- Position for stopping the raising movement.
- Position for raising the chassis to its highest position (lever anti-clockwise in outer position).











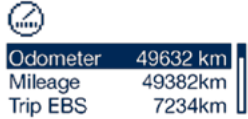

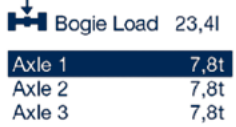
**The position of the raising and lowering valve may only be changed to another position from the driving position during loading and unloading.**

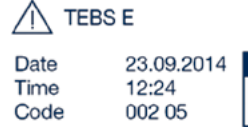
## D. SYSTEM DESCRIPTIONS

### 4.3. SMARTBOARD

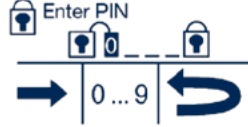
#### General

 <p>Odometer</p>	 <p>Lining wear</p>	 <p>Axle load indication</p>	 <p>Switch options</p>
 <p>Tire monitoring</p>	 <p>Messages</p>	 <p>Air suspension</p>	 <p>Extra's</p>
 <p>Road finisher brake</p>	 <p>Immobilizer</p>	 <p>Vehicle inclination</p>	 <p>Language</p>

Certain functions are not standard. Those can be obtained through options

## D. SYSTEM DESCRIPTIONS

### Electronic kilometre indicator through SmartBoard

The electronic kilometre indicator can be read on the SmartBoard (see Figure 4.3.1.a.).

The electronic kilometre indicator is used to:

- verify in a simple manner how many kilometres the trailer has travelled,
- plan the maintenance of the trailer by the number of kilometres travelled.

Odometer: kilometre recorded by SmartBoard = Total number of kilometres (independent of the power supply)

Mileage: number of kilometres recorded by EBS (with power supply)

Trip EBS: trip mileage EBS (with power supply – can be set on 0 (only with PC))

Trip: trip mileage counter SmartBoard (with power supply – can be set on 0 with SmartBoard)

#### 4.4. LOAD INDICATION THROUGH SMARTBOARD AND ANY POSSIBLY CALIBRATION

The SmartBoard gives an “indication” of the total axle load or the load on the axles separately (see figure 4.3.1.a.).



**It is strictly forbidden to exceed the maximum bags pressure stated on the brake plate (see § 3.6).**

#### Calibration

##### Pressure sensor calibration



**Rolling vehicle  
Position the vehicle on an even surface and secure it against rolling away with use brake wedges. Only use approved devices to jack up and secure the vehicle.**



**Risk of injury due to brake action while working on the brake  
Attach a clearly marked note on the steering wheel saying that work is being performed on the vehicle and that the brake must not be touched.**

The SmartBoard provides the option to calibrate the pressure sensor to improve the accuracy of the axle load indication of Trailer EBS E.

This will improve the accuracy of the axle load indication. The more accurate the vehicle weight is determined and the pressure sensors are calibrated, the more exact the axle load is displayed. In case of a wrong calibration on the axle load indicates wrong values!

The actuation of brake pressures is unaffected by this calibration, these values apply to parameter settings provided by vehicle manufacturer.

##### Calibration points

The larger the weight difference between individual calibration points, the more exact the axle load indication will be. The calibration point “partially loaded” is an option and not necessarily used.

- Empty
- Partially loaded (optional)
- The vehicle weight in the partially loaded condition should be the midpoint between vehicle weight in empty and fully loaded condition.
- Loaded

##### Preconditions

- Trailer EBS E1 with software version from TE14013 upwards
- SmartBoard met software vanaf SB010207



**During calibration, the parking brake and service brake must be released.**

### Calibration on the semi-trailer

Determine the weight of semi-trailer in unladen, partially laden (optional) and laden weight using calibrated weighing device. Ensure that all axles of the semi-trailer are located on the weighing device.

Working method:

- Select the menu <extras> <settings> <sensor calibration>.
- For vehicles with raised lifting axle(s) you will be requested to lower them.
- Lower the lifting axle(s) by pressing button <arrow right>.
- The calibration will continue when all lifting axle(s) are lowered.
- Select the menu item <calibrate unladen.> and enter the weight of unladen semi-trailer.
- Button <arrow right>: changes the digit position
- Button <OK>: changing the value
- Button <back>: confirmation of input
- Confirm saving the entered calibration data by pressing the <OK> button.
- A successful calibration is indicated by displayed icon with check.
- Repeat the last two action steps for the partly loaded (optional) and the fully loaded semi-trailer.
- To do this, select the corresponding menu items <calibrate partly laden.> and <calibrate full laden.>

## 5. WHEEL ACCESSORIES

### 5.1. TYRES AND RIMS

All wheels and tyres mounted on the trailer are identical. A number of options with regard to make, size, offset and profile of wheel/tyre are available, but these should always comply with the technically permissible axle loads, the load-speed index and the brake schedule.



**In the interest of safety it is extremely important to respect the correct tyre pressures.**

**Tire pressure has a significant impact on stability during tipping. It is strictly forbidden to unload when the tire pressure is not correct.**

Driving on tyres with insufficient pressure causes an abnormal rise in temperature which damages parts of the tyres. This damage is irreversible and will in due course unavoidably lead to flat tyres. The consequences of insufficient tyre pressures are not always immediately visible and may only become apparent long after the tyre pressures have been corrected.



**The valve cap is essential for complete air-tightness and for protection of the inner valve.**

**Tyre pressures are stated on the sticker located on the side of the trailer at the first axle.**

### 5.2. TIRE PRESSURE MONITORING

Stas vehicles are equipped with a regulatory tire pressure monitoring system. If there is something wrong with the tire pressure of your trailer, the following icon, possibly accompanied by other warnings, will light up on the dashboard of your truck. Check your truck's manual to see what the correct indication of this light means.



Figure 5.2.a. The icon can be displayed in both red and orange.



**The tire pressure monitoring system does not relieve the user of the duty to periodically check the condition of the tires.**

## D. SYSTEM DESCRIPTIONS

### Identification

To see which tire pressure monitoring system is installed, you can simply look at the wheels of the vehicle. A TPRS system (Tire Pressure Refill System) inflates the tires when there is insufficient pressure and is easily recognizable by the air hose that runs from the hub of the axle to the valve.



Figure 5.4.b. Air hose from hub to valve in a TPRS system.

If you do not see any air hoses, your vehicle has a TPMS system (Tire Pressure Monitoring System). In this case, sensors are mounted on the rim inside the tire, which relay the pressure and temperature of the tire to the trailer and truck.

### TPRS (Tire Pressure Refill System) – Automatic Tire Inflation System

The TPRS system automatically inflates the tire(s) when the pressure in one or more tires drops by 0.2 bar or more. The warning light will briefly light up or blink in the tractor when the system is active. You can continue driving but should check the tires and the system at the next stop. If the warning light stays on continuously, the system cannot compensate for the pressure loss, and you should stop as soon as possible. Have the tires and the system inspected by a tire specialist.

### TPMS (Tire Pressure Monitoring System) – Tire Pressure sensors

If you do not have an automatic tire inflation system (TPRS), your vehicle is equipped with tire pressure sensors that send a warning signal to the tractor and on the Smartboard. When the pressure in one or more tires drops by 0.2 bar or more, the warning light will illuminate in the truck. You should stop immediately and visually inspect the condition of the tires to ensure that the cause of the warning is not due to any damage to the tire. Tire pressure must be restored to 9 bar as soon as possible.

After refilling the tire(s), turn off the ignition for a few seconds to reset the warning light. Contact your STAS dealer or the nearest tire specialist if the warning light re-illuminates shortly after.

### Replacing Sensors and Wheels

When mounting a spare wheel, the warning light will remain on until the new sensor(s) are programmed. Contact your STAS dealer or tire specialist for assistance with this.

### 5.3. SPARE WHEEL AND SPARE WHEEL CARRIER

The spare wheel is located as standard in the single spare wheel carrier on the passenger side of the vehicle. The spare wheel can be reached by folding the side guards upwards. In order to lift the spare wheel from its carrier, remove the safety bar which keeps the spare wheel in position. An optional double spare wheel carrier may be fitted.



Figure 5.2.a. – Single spare wheel carrier



The maximum load is 140 kg for a single spare wheel carrier and 250 kg for a double spare wheel carrier.

The spare wheel should be securely fastened to the spare wheel carrier at all times in order to avoid damage, coming loose or losing the spare wheel.

## D. SYSTEM DESCRIPTIONS

### 5.4. WHEEL CHOCK

The use of the wheel chock is strongly recommended when uncoupling the trailer. This must also be done when on an apparently not inclined surface.



**Do not forget to remove the wheel chock and return it to its holder once the trailer has been coupled.**



Figure 5.3.a. – Wheel chock in holder (left) and in place (right)

### 5.5. MUD GUARDS AND MUD FLAPS

There are two types of mud guards which comply with the legal requirements. The first type covers the wheels collectively using part of the chassis and the second type covers the wheels individually. Both types of mudguards are fitted with mud flaps that, depending on the legal regulations in the country concerned, are fitted with brushes (anti-spray).



Figure 5.4.a. – Types of mudguards



Figure 5.4.b. – Mud flap with brushes



**The spray suppression on the mud flaps should be cleaned on a regular basis by means of a high pressure cleaner.**

### 6. DOORS

#### 6.1. BARN DOOR

##### Description



Figure 6.1.1.a. – Barn door with swingable top bar

A barn door is a double door that opens sideways on vertical hinges. A barn door can optionally be fitted with one or a number of grain hatches. Barn doors can be in a symmetric or asymmetric form. The top bar (that the barn door locks into) can be provided swingable or otherwise.

##### Opening and closing the barn doors



**Prior to opening the door, ensure:**

- the load allows you to do so safely,
- the load cannot suddenly fall out,
- there is no one in the vicinity who could get trapped between the doors and/or side walls,
- there is sufficient space to open the doors outwards.

**Open the barn doors before tipping, never during the tipping.**

To open the door:

- Remove the safety catches (1) of the operating levers (see Figure 6.1.2.a.).
- Turn the two levers (2) towards each other to free the lock opening.
- In the almost squared position pull the levers back so they are no longer locked in the lock holder.
- Open the doors to the sides of the vehicle.
- Attach the doors to the side wall using the lock for that purpose.

To close the doors:

- Proceed as above in reverse order.



**Once the doors have been closed, please ensure:**

- the top and bottom locking cams of the doors are positioned correctly in their holders,
- that the operating levers are fixed with the safety catches.



Figure 6.1.2.a. – Closing safety system

## D. SYSTEM DESCRIPTIONS

For the operating of the optional grain hatches see § 8.2.

Optional: opening the door from the side of the trailer.

When access behind the trailer is restricted (e.g. by the presence of a pit) a provision is available that allows the opening of the barn doors from the side of the trailer.



Figure 6.1.2.b. – Optional: opening barn door from the side of the trailer

- Unlock the safety catches of the operating levers. Do this before access behind the trailer is restricted.
- Pull the operating cord. Do this from the side of the trailer. The levers are then unlocked.
- The door will fully open when tipping starts.

### 6.2. TOP HINGED DOOR

#### Description



Figure 6.2.1.a. – Top hinged door

The top hinged door is suspended on 2 hinge points on top of the rear stand. After unlocking, the top hinged door will make a swinging movement when tipping causing an opening at the bottom of the door of the tipping body to unload the load.

#### Opening and closing a top hinged door



Prior to opening the door, ensure:

- the load allows you to do so safely,
- the load cannot suddenly fall out,
- there is no one in the danger zones (between tipping body and chassis, just behind the vehicle, etc.), and there are no persons or animals within tipping range.

Unlock the top hinged door before tipping, never during tipping.

If the unlocking of the top hinged door is done by a supervisor, he must be familiar with the working of the trailer. He must comply with the safety instructions at all times.

#### Opening the top hinged door

First manually unlock the locking hook safety catches. These are found near the locking hooks (see Figure 6.2.2.a.) or near the pneumatic cylinder that operates the locking hooks (see Figure 6.2.2.b.). Stand at the side of the trailer and beware of the accidental opening of the safety catches or top hinged door.



Figure 6.2.2.a. – Safety catch locking hooks top hinged door (unlocked left; locked right)

The locking hooks of the door can then be operated. This can be by:

- a valve on an operating console on the side (see Figure 6.2.2.b.).
- a blocking valve fitted under the tipping body near the landing legs (see Figure 6.2.2.b.). This valve automatically opens the hooks when tipping.
- an electrical valve operated from the lorry.

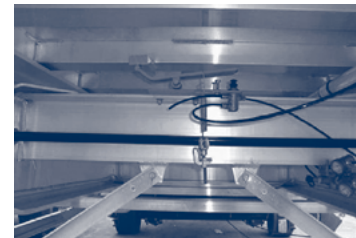

Figure 6.2.2.b. – Blocking valve for operation of locking



Figure 6.2.2.c. – Operating valve on separate console



## D. SYSTEM DESCRIPTIONS

### Closing the top hinged door

- When the tipping body is resting on the chassis the locking hooks are closed by the electric valve in the lorry or by the operating valve. With trailers with a blocking valve the locking hooks close automatically.
- Check that the locking hooks lock the door.
- Slide the safety catches to the locked position.

### Switching off the automatic operation of the locking hooks (with blocking valve)

- The automatic operation of the locking hooks with blocking valve can be switched off. The operating valve is closed to do this. Now compressed air can no longer be supplied to the pneumatic cylinders, so when tipping the top hinged door will not open.
- To reactivate the automatic operation of the locking hooks the operating valve must be put back in the open position.

For the operation of the optional grain hatches see § 8.2.

### 6.3. UNIVERSAL DOOR

#### Description



Figure 6.3.1.a. – Universal door as barn door (left) and as top hinged door (right)

A universal door is a combination of a barn door and a top hinged door.

#### Operation

Operation as barn door

- See § 6.1.2.

Operation as top hinged door

- See § 6.2.2.

For the operation of the optional grain hatches see § 8.2.

### 6.4. LEAKPROOF REAR DOOR

#### Description



Figure 6.4.1.a. – Single-part leakproof door

The leakproof rear door is a single-part door provided with leakproof sealing between the door and the door frame. The door can open single-acting or universal. This allows less solid goods to be transported without the excessive leakage of goods from the vehicle.

A combination of closing hooks (swinging or other to not obstruct the unloading) and clamps is used to guarantee leakproofness. The swinging closing hooks consist of a combination of hydraulic hand pump, cylinder, worm gear and closing hooks. The hydraulic hand pump forces oil into the cylinder that drives the worm wheel. This worm wheel causes the rotating movement of a shaft with closing hooks. The closing hooks lock the door, or unlock it and fold the door completely away.

With a single-acting door hydraulic closing hooks are used for both horizontal and the vertical locking (horizontal closing hooks can be swung away).

With a universal door, hydraulic swing-away closing hooks or traditional closing hooks are used for horizontal locking. The leakproof rear door can also be fitted with a grain hatch. This grain hatch must not be used to unload goods that must be transported "watertight". It is only provided to be able to unload goods not to be transported "watertight". A plate with seals is assembled on the inside of the door to ensure the watertightness of the rear door. This must be folded upwards and bolted tight if one wishes to use the grain hatch (see Figure 6.5.1.b.).



Figure 6.4.1.b. – Grain hatch on leakproof door, plate with seals folded away



Prior to opening the door, ensure:

- the load allows you to do so safely,
- the load cannot suddenly fall out,
- there is no one in the vicinity who could get trapped between the doors and/or side walls,
- there is sufficient space to open the doors outwards.

Open the door before tipping, never during tipping.

## D. SYSTEM DESCRIPTIONS

### Opening the door as a barn door.

- Loosen the clamps on the door.
- With a universal door the screw key operating hook must be brought downwards.



Figure 6.4.2.a. – Operating hook screw key upper position (screw key locked)

- Check that the hinge pin is sitting firmly in the bottom hinge.
- Open the closing hooks (both horizontal and vertical). First ensure the mechanical locking is unlocked, then open the closing hooks. The swinging closing hooks are opened by a hydraulic hand pump. Customary pneumatic closing hooks are opened by a valve at the front and/or at the rear (also see § 6.2).
- Open the door.

Closing the door is done in reverse order. Do not forget to tighten the clamps in order to guarantee the watertightness of the door.

### Operation as top hinged door



#### Prior to opening the door, ensure:

- **the load allows you to do so safely,**
- **the load cannot suddenly fall out,**
- **there is no one in the danger zones (between tipping body and chassis, just behind the vehicle, etc.), and that there are no persons or animals within tipping range.**

**Unlock the door before tipping, never during tipping.**

**If the unlocking of the door is done by a supervisor, he must be familiar with the working of the trailer. He must comply with the safety instructions at all times.**

### Opening the door as a top hinged door.

- Loosen the clamps on the door.
- With a universal door make sure the operating hook of the screw key is upwards, i.e. the screw key is in the closed position (see Figure 6.5.2.a.).
- Remove the hinge pin from the bottom hinge.
- Open the closing hooks (both horizontal and vertical). First ensure the mechanical locking is unlocked, then open the closing hooks. The swing-away closing hooks are opened by a hydraulic hand pump. Customary pneumatic closing hooks are opened by a valve that at the front and/or at the back (also see § 6.2) or by a blocking valve (see Figure 6.2.2.d.).

### Closing the door as a top hinged door

- When the tipping body is resting on the chassis the closing hooks close (both the horizontal and vertical). With trailers with a blocking valve the closing hooks close automatically.
- Check that the closing hooks look the door body and put the mechanical locking in the locked position.
- Place the locking pin in the bottom hinge again.
- Tighten the clamps to ensure with the watertightness of the door

For operation of the optional grain hatches see § 8.2.

## 6.5. HYDRAULIC TOP HINGED DOOR

### Description



Figure 6.5.1.a. – Tipper with hydraulic top hinged door

A hydraulic door can only be used as a single-part top hinged door.

The opening of the hydraulic top hinged door is done by two hydraulic cylinders (one on each side).

The hydraulic flow chart of a tipper with hydraulic top hinged door is clarified in Figure 6.6.1.b.

The hose with hydraulic oil (from the lorry) is connected to the 3/4" (or other) coupling. This is connected to a collector (2). The collector (2) has a hose connection with the tipping cylinder (1). The tipping cylinder (1) can be switched off with a ball valve (3). From the collector (2) there is also a connection to the two hydraulic cylinders for the top hinged door (9). These have hose breakage valves (10) to keep the (half) opened hydraulic top hinged door in position should the connections break. A flow controller (4) and a ball valve (5) are fitted between the collector and hydraulic top hinged door cylinders. This ball valve (5) can also be provided as an electrically operated (from the lorry) valve. The flow controller (4) restricts the quantity of oil to the top hinged door hydraulic cylinders. The ball valve (5) enables the switching off of the top hinged door.

The hydraulic top hinged door is provided in combination with a blocking valve (6) for the operation of the locking hooks. When the tipping body tips a little upwards the blocking valve sends air pressure from the reservoir (7) to the pneumatic cylinders (8). These pneumatic cylinders (8) open the locking hooks. With the lowering of the tipping body the blocking valve shuts off the air pressure from the reservoir and the pneumatic cylinders (8) are relieved. A spring closes the locking hooks. The working of the blocking valve can be switched off using an operating valve (11).

## D. SYSTEM DESCRIPTIONS

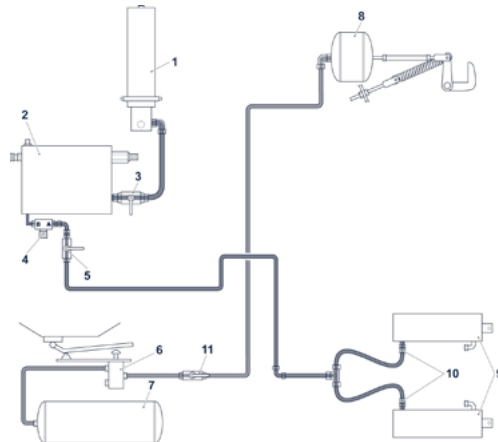

Figure 6.5.1.b. – Diagram Tipper with hydraulic top hinged door

### Normal operation

#### Tipping of the body

Oil is sent from the lorry to the collector (2). On the one hand this oil goes to the tipping cylinder (1) and on the other hand to the hydraulic cylinders of the top hinged door (9) (this at a lower rate than the tipping cylinder through the flow controller). The top hinged door does not open as long as the locking hooks are not opened. When the tipping body has tipped a little the blocking valve (6) is operated so the locking hooks open. As from now the tipping movement is combined with the opening of the hydraulic top hinged door. The flow controller (4) restricts the opening speed of the hydraulic top hinged door, and is set so that the hydraulic top hinged door is fully opened prior to the tipping body reaching its highest position.

#### Lowering the body

The oil is released to the reservoir by the lorry. The oil flows simultaneously through the collector (2) from the tipping cylinder and cylinders of the hydraulic top hinged door. The flow controller (4) is set so that the cylinders of the hydraulic top hinged door empty more quickly than the hydraulic tipping cylinder. The hydraulic top hinged door will therefore be closed before the tipping body rests on the chassis (i.e. the time that the blocking valve (6) is no longer operated). This allows the locking hooks to lock the top hinged door.

### Isolated working

By operating the ball valves for the tipping cylinder (3) or the top hinged door hydraulic cylinders (5) one can switch off the working of the respective cylinders.

To only tip (without opening the top hinged door) one closes the ball valve of the top hinged door hydraulic cylinders (5) and switches off the working of the locking hooks with the operating valve (11).

To only operate the top hinged door one must close the ball valve of the tipping cylinder (3). The top hinged door will only open when the locking hooks are unlocked. This is done by tipping the body a little beforehand so the blocking valve (6) is operated.

### Operation



**Never enter the working range of the hydraulic top hinged door. The top hinged door can make movements unexpected by the operator and bystanders when tipping, with the lowering of the tipping body and with the isolated working of the hydraulic top hinged door.**

**The opening and closing of the hydraulic top hinged door normally takes place in combination with unloading the trailer (tipping). Respect the specific safety instructions for this procedure (see § E.2.3)**

### Operating at normal functioning

- Manually unlock the locking hook safety catches (near the locking hooks or near the pneumatic cylinder).
- Carry out the tipping procedure (see § E.2.3.2). The hydraulic top hinged door automatically opens when tipping. The hydraulic top hinged door closes automatically with the lowering of the tipping body.
- Check that the locking hooks look the door body.
- Slide the safety catches into locked position.

### Operating at isolated functioning of the tipping cylinder and rear door

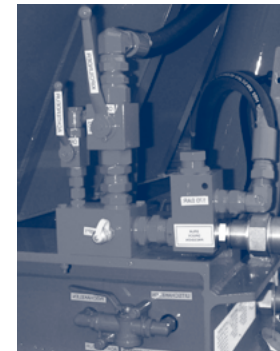

Figure 6.6.2.a. – Position of ball valves for isolated functioning of tipping cylinder and rear door

The operating controls for isolated working are displayed (Figure 6.6.2.a.). The large vertically fitted ball valve corresponds to ball valve (3) on the diagram (Figure 6.6.1.b.). The small vertically fitted ball valve corresponds to ball valve (5) on the diagram. The horizontally fitted operating valve (on the chassis beam) corresponds to operating valve (11) on the diagram.

### Tipping without opening the top hinged door



**Tipping without opening the top hinged door may only take place with use of a grain hatch or when tipping without a load.**

**Respect the specific safety instructions for tipping (see § E.2.3.2).**

- Shut the ball valve (5) on the diagram (Figure 6.6.1.b.) that operates the top hinged door hydraulic cylinders.
- Shut the operating valve (11) so the locking hooks cannot open.
- Make sure that the locking hooks are also mechanically locked.
- Allow the tipping body to tip and lower again.
- Open the operating valve (11) and the ball valve (5) so the hydraulic top hinged door does automatically open with the following tipping cycle.

## D. SYSTEM DESCRIPTIONS

### Opening and closing the hydraulic top hinged door (without full tipping cycle)



Never enter the working range of the hydraulic top hinged door.

If you go into the tipping body through the opened hydraulic door, this must be mechanically secured against accidental closing.

- Open the roof sheet. For the specific procedure for the opening of the specific type of roof cover see § 7.2, § 7.3 or § 7.4.
- Connect the hydraulic circuit of the lorry to the cylinder. One hydraulic hose is connected with a single hydraulic circuit. A double hydraulic circuit has a second hose (from the pressure relief valve) that is connected back to the oil reservoir.
- Manually unlock the locking hook safety catches.
- Check if there is no one in the danger zone (behind the hydraulic door).
- Switch on the lorry's hydraulic set (usually using the PTO) and start slowly tipping the tipping body until the locking hooks are open.
- Shut the ball valve (3) on the diagram (Figure 6.6.1.b.).
- Check that the hydraulic top hinged door fully opens.
- Switch off the lorry's hydraulic set (usually by the switching off the PTO).
- To close the hydraulic top hinged door the oil must be allowed back to the reservoir (using the hydraulic set on the lorry).
- After the top hinged door has closed, the ball valve (3) must be opened again so the tipping body lowers to its horizontal position and the locking hooks automatically close.
- Disconnect the hydraulic connections after the tipping body has returned to its horizontal position (rest position).
- Manually lock the locking hooks.
- Close the roof sheet if necessary

### 7. ROOF COVERING

Various versions of roof covering are available:

- a roof sheet rolling side to side (see § 7.2),
- Roof sheet that can be operated from the ground, type "Dawnbarn"
- Roof sheet that can be operated from the ground, type "Cramaro"

#### 7.1. CATWALK WITH LADDERS

Most trailers are equipped with a catwalk which can be accessed using the associated ladders. This area serves as a catwalk for the operator who can use it to:

- open or close the sheet in an efficient and safe way,
- check whether the load is not stacked too high or distributed unevenly after the loading process.



Figure 7.1.a. - Catwalk (examples)

The catwalk contains a fixing point for a safety harness. This harness prevents the operator from falling off the catwalk. However, it is not supplied with the trailer.



- Prior to accessing the ladder to the catwalk, ensure the ladder rungs as well as your shoes are free of mud or other substances which could cause you to slip.
- Always use both hands when climbing up or down ladders. Use 3 supporting points at all times (2 feet and 1 hand or 1 foot and 2 hands).
- Always use a safety harness which has been attached to the fixing point on the catwalk.
- Access to the catwalk should not be used for watching the loading or unloading process.

#### 7.2. ROLL-OVER ROOF SHEETING SYSTEM

##### Description

The roll-over roof sheet provides a perfect seal for the trailer and is attached to:

- the front of the trailer by means of a continuous rubber band or brackets,
- on one side of the trailer by means of tensioning straps or slats,
- on the other side of the trailer by means of a permanent attachment.

The roll-over roof sheet is fitted with a roll-up slat into which a winding handle can be fitted. This winding handle is either attached to the catwalk support or it can be found inside the roll up slat where it will be fastened by a rubber band. The winding handle enables the operator to roll the roof sheet up or down.



Figure 7.2.1.a. - Attachment winding handle

##### Use of the roll-over roof sheet

Prior to rolling up the roll-over roof sheet, the fasteners on the front and left will have to be loosened. Roll stops should also be fitted to prevent the roll-over roof sheet from rolling off the trailer. The straight roll stop partly holds the roll-over roof sheet above the loading area. With the buckled roll stop the roll-over roof sheet lies "alongside" the body.

The roll stops can be fixed using the supplied ladder that is attached to the chassis or tipping body. After the shutting of the roll-over roof sheet the roll stops must be removed and stored in the place for that purpose.

## D. SYSTEM DESCRIPTIONS



- For safety reasons it is important to check whether the roll stops have been correctly fitted prior to rolling up the roll-over roof sheet.
- Buckled roll stops should only be used on private sites.
- If one drives with open roll-over roof sheet on the public highway, the roll-over roof sheet considerably increases the total height of the trailer.
- The roll-over roof sheet may not be used to help flatten the load.
- Never drive with half open roll-over roof sheet.
- It is forbidden to climb onto or walk on the roof sheet.



Before departure, the driver has to make sure that there are no loose parts (for example ice floe, water, tools, etc.) on the roof covering.

### 7.3. ROOF SHEETING SYSTEM, TYPE "DAWNBARN"

#### Description



Figure 7.3.1.a. - "Dawnbarn" type roof sheeting system

The Dawnbarn type roof sheeting system consists of a roof sheet with a rod operated by means of a crank. The sheet is rolled up in the longitudinal direction of the vehicle.

There is a design where the roof sheet is rolled on a rod on the side of the tipping body. A second design has the rod in the middle of the tipping body. The rod is rolled to the side of the trailer, the right and the left part of the roof sheet then roll up "over each other".

#### Operation

The operation of the roof sheet preferably takes place from the road surface. If circumstances do not allow this, operation can also take place from the catwalk.

#### Opening the roof sheet, type "Dawnbarn", from the road surface (see Figure 7.3.1.a.)

- Fit the necessary roll stops so the roof sheet cannot roll off the trailer. The straight roll stop partly holds the roll-over roof sheet above the loading area. With the buckled roll stop the roll-over roof sheet lies "alongside" the body.
- Take the pull back cord from the material box and fasten it with the safety hook to the D-ring provided on the tensioning strap in the middle of the vehicle.
- Loosen all tensioning straps and/or other fastening systems for the roof sheet with the ratchets and tensioners provided for this. The tensioning straps can be provided with a steel profile that is hooked onto the roof sheet. The roof sheet can then easily be removed or tightened from the ground.



Figure 7.3.2.a. - Fastening pull back cord and loosening of roof sheet

- Take the long winding handle from its storage position in the chassis.
- Place the tapered head in the opening at the back of the roller tube. Make sure the anchoring pins in the tube are firmly in place.
- Turn the lever with 2 hands to roll up the roof sheet up against the roll stops (see Figure 7.3.2.a.).
- Remove the winding handle from the roller tube and put it back in its storage position in the chassis.

#### Opening from the catwalk (see Figure 7.3.2.b.)

- Fit the necessary roll stops so the roof sheet cannot roll off the trailer. The straight roll stop partly holds the roll-over roof sheet above the loading area. With the buckled roll stop the roll-over roof sheet lies "besides" the body.
- Loosen all tensioning straps and/or other fastening systems for the roof sheet with the ratchets and tensioners provided for this.
- Take the short winding handle from its storage position in the chassis.
- Proceed on to the catwalk and place the tapered head in the opening at the back of the roller tube. Make sure the anchoring pins in the tube are firmly in place.
- Turn the lever with 2 hands to roll up the roof sheet up against the roll stops.



The roof sheet has a crossing to guarantee the waterproof sealing of the tipping body. This crossing is also rolled up and impedes rolling up somewhat. Make sure one does not fall of the catwalk.

- Remove the roll-up lever from the roller tube and put it back in its storage position in the chassis.



Figure 7.3.2.b. - Operating of Dawnbarn from catwalk

## D. SYSTEM DESCRIPTIONS

### Closing the roof sheet, type "Dawnbarn", from the road surface (see Figure 7.3.2.c.)

- If the roof sheet was opened from the road surface a pull back cord must be fixed to it. Pull the pull back cord until the roof sheet has fully unrolled.
- Tighten all tensioning straps and/or other fastening systems for the roof sheet with the ratchets and tensioners provided for this. Make sure that the tensioning straps are sufficiently tight but do not bend the roller tube.
- Remove the pull back cord from the D-ring on the tensioning strap in the middle of the vehicle. Put the pull back cord back in the tool box.



Figure 7.3.2.c. – Closing the roof sheet, Dawnbarn type, with pull back cord and tightening the sheet

### Closing the roof sheet, type "Dawnbarn" from the catwalk (see Figure 7.3.2.b.)

- Take the short winding handle from its storage position in the chassis.
- Proceed on to the catwalk and place the tapered head in the opening at the back the roller tube. Make sure the anchoring pins in the tube are firmly in place.
- Turn the handle with 2 hands to unroll the roof sheet until the roof sheet has fully unrolled.
- Remove the winding handle from the roller tube and put it back in its storage position in the chassis.
- Tighten all tensioning straps and/or other fastening systems for the roof sheet with the ratchets and tensioners provided for this. Make sure that the tensioning straps are sufficiently tight but do not bend the roller tube.

## 7.4. ROOF SHEETING SYSTEM, TYPE "CRAMARO"

### Description



Figure 7.4.1.a. – Roof sheeting system type "Cramaro"

The Cramaro type roof sheet is folded up back to front using a folding device. This can be done manually (crank) or electrically.

### Operation



- It is forbidden to drive with the "Cramaro" roof sheet without it being fully closed.
- The roof sheet may not be used to help flatten the load.
- Electrical components of the "Cramaro" roof sheeting system may not be sprayed with water.
- The pulleys and metal tensioning cables may not be lubricated.
- Never leave the operating key in the control panel when the roof sheet is not being operated.
- It is forbidden to climb onto or walk on the roof sheet.
- It is forbidden to drive with strong winds and/or gusts.
- The roof sheet may not be operated while it is being maintained.

### Manually operated roof sheet, "Cramaro" type

- Remove the tensioning cables of the roof sheet to the rear and side of the trailer.
- Loosen the crank (see Figure 7.4.2.a. left) or fix the lever in the gearbox spindle (see Figure 7.4.2.a. right)
- Turn the crank or the lever clockwise or anticlockwise until the roof sheet is fully open or closed.
- Fix the crank again or remove the lever from the gearbox.
- When the roof sheet has been shut again, pull the rear part of the roof sheet over the rear door. Then fasten then the roof sheet tensioning cables to the anchor points at the rear and side of the trailer.

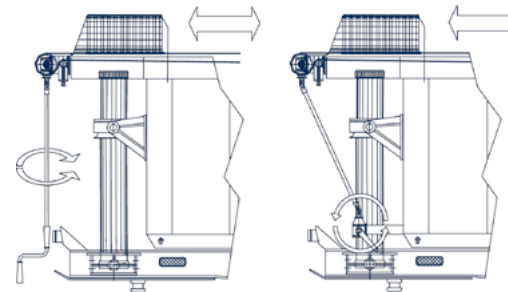

Figure 7.4.2.a. – Manuale bediening dekzeil type "cramaro"

### Electrically operated roof sheet, type "Cramaro"

Operation takes place using a control panel on the side of the trailer (see Figure 7.4.2.b.).

- Remove the tensioning cables of the roof sheet to the rear and side of the trailer.
- Insert the key in the middle of the emergency stop (the emergency stop is on the side of the control panel).
- Open the control panel door
- The roof sheet can be opened or closed with the selector switch (3) (see Figure 7.4.2.c.). The indicator light (2) is on while roof sheet is moving.
- If an obstacle is encountered when opening or closing the roof sheet the safety fuse (1) will activate and the movement of the roof sheet will stop. Remove the obstacle, reset the safety fuse and try to open or close the roof sheet again with the selector switch (3).
- If a problem occurs the emergency stop can be pressed. This is reset with the key.
- When the roof sheet is fully open or closed, close the control panel door, remove the key and press the emergency stop. This prevents unauthorised use.
- When the roof sheet is closed, fix the tensioning cables to the anchor points on the side and rear end of the trailer.

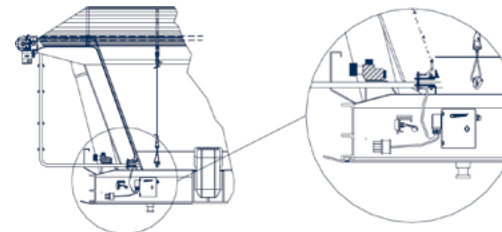

Figure 7.4.2.a. – Electrically operated roof sheet, type "Cramaro"

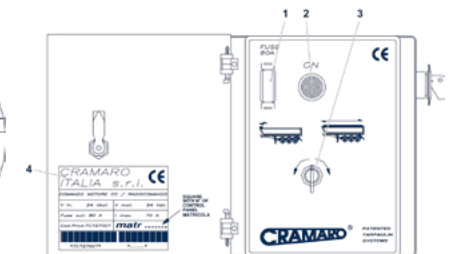

Figure 7.4.2.c. – Operating panel, electrically operated roof sheet, type "Cramaro"

## D. SYSTEM DESCRIPTIONS

### 8. TIPPER ACCESSORIES

#### 8.1. TOWING HOOK

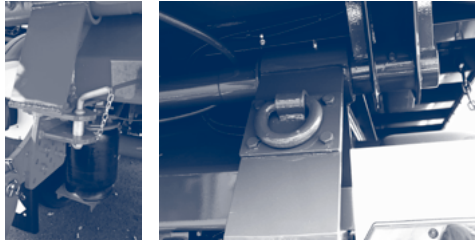

Figure 8.1.a. – Towing hook

The towing hook is fitted at the back of the trailer.



**Only use the towing hook for towing another vehicle. The towing hook must not be used to pull out stuck vehicles (excessive load).**

#### 8.2. GRAIN HATCH

##### Description



Figure 8.2.1.a. – Different types of grain hatches

The grain hatch is a closable opening incorporated in the rear door. This is fitted to the tipper with the purpose of loading a free-flowing product or products in smaller quantities (use of a conveyor belt).

There are two types of grain hatch. The type with lever it is opened by pulling the lever down. The type with rack and pinion uses a rod with a ratchet spanner. This rod is connected to a gear wheel. The gear wheel is connected with a gear rack, fitted on the grain hatch. Turning the rod (with the ratchet spanner) moves the gate upwards.

The gate is opened by operating the lever. The grain hatch is also optionally provided with a dust sleeve (see Figure 8.2.1.b.).



Figure 8.2.1.b. – Door with grain hatch with dust sleeve

##### Use



- **When tipping through the grain hatches one must ensure that the tipping body is not too high so the load does not exert excessive pressure on the doors.**
- **The operator must ensure that during unloading no persons are in the danger zones (between the tipping body and chassis, just behind the vehicle) and that no persons or animals are within the operating range where the tipping is taking place.**
- **Never put any limbs in the grain hatch.**

Unloading by means of the grain hatch

- Check that the doors are locked. Check that the mechanical locking is in the right position and that any pneumatic locking (locking hooks) has been operated.
- Fit the optional dust sleeve (this is located on the side of the trailer) and remove the elastic strap binding the dust sleeve (see Figure 8.2.1.b.).
- Check that there is no one within a radius of 2 metres around the grain hatch.
- Open the grain hatch

With the type with the lever, the clamp on the hinge point of the lever is first released, and the lever is pulled down until the hatch is in the required position. Lock this position with the clamp on the hinge point. Make sure you are as far as possible to the side of the trailer away from the opening.

## D. SYSTEM DESCRIPTIONS

With the type with rack and pinion one must fit the ratchet spanner (from the tool box) on the rod. One can then open the grain hatch to the required position. Lock the rod in the required position.



Figure 8.2.1.c. – Operation and locking of the grain hatch, type with rack and pinion



**When opening the grain hatch always pay attention to the outflowing load. Open the grain hatch from the side of the vehicle to the extent possible.**

- Tip the body gradually so that there is a sufficient amount of the load at the chute without there being excessive pressure on the doors.



**Never tip the body fully upwards in one movement. The pressure exerted by the load on the closed rear door can be too high.**

- After unloading bring the tipping body back into the horizontal position.
- Close the grain hatch and lock it in its closed position. Make sure that the ratchet is put back in the tool box.
- Remove the dust sleeve, store it compactly (using the elastic strap) and put it back in its place on the side of the trailer.

### 8.3. BODYGUARD

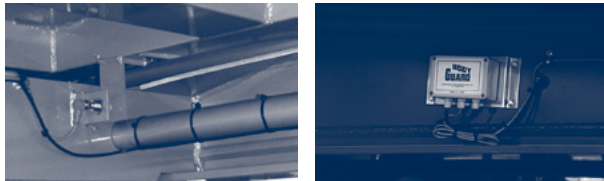

Figure 8.3.a. – Bodyguard (left: main control unit right: proximity switch with detection plate)

The bodyguard is a system that generates a noise and visual signal when tipping. It consists of a proximity switch (that detects a tipping body detection plate when it is resting on the chassis), a main control unit and a visual warning appliance (control light assembled on a place visible to the driver from his cab).

#### Operation

After the ignition has been switched on the bodyguard will be active for approximately 5 seconds. This makes the driver aware of the bodyguard being operational. A pulsed signal is generated when a cable or sensor is damaged.

When the tipping body rests on the chassis the proximity switch detects the metal mass of the detection plate. The warning system is then switched off.

When the tipping body is no longer resting on the chassis (due to an action of the operator or another cause) the proximity switch will detect the absence of the detection plate. This causes a pulsed audible and visual signal. This signal remains active until the tipping body rests on the chassis again or until the ignition is switched off.



## D. SYSTEM DESCRIPTIONS

### 8.4. HINGED REAR UNDER-RUN BAR

#### Description

A hinged rear under-run bar is available for all models. This usually functions as an aid when unloading a load in an asphalt machine.

#### Version with manually hinged rear under-run bar

Here the rear under-run bar is locked with safety catches. See Figure 8.4.1.a.

#### Version with automatic hinged rear under-run bar – operated from the lorry cabin

See Figure 8.4.1.b.



Figure 8.4.1.b. – Automatic hinged rear under-run bar

#### Operation of automatically hinged rear under-run bar

Hinging the rear under-run bar

- Make sure you are on the site and not on the public highway.
- Check that there is no one in the danger zone at the back the vehicle.
- Check that the body is still resting on the chassis (tipping not started).
- Switch the electrical button in the cab to the "1" or "ON" position. The rear under-run bar will now gradually fold up. A buzzer at the back the trailer sounds during folding up.
- Leave the power switched on so the rear under-run bar remains in the hinged position.

Lowering the rear under-run bar

- Check that there is no one in the danger zone at the back of the vehicle.
- Check that the body is resting on the chassis again (tipping ended).
- Switch the electrical button in the cab to the "0" or "OFF" position. The rear under-run bar will now gradually fold down.
- Make sure of the correct position of the rear under-run bar before driving back on the public highway.



**Two levers are supplied with the automatic hinged rear under-run bar to allow the blocking of the installation. Use these levers if you have to work at the back of the vehicle. The levers are located to the left at the back on the chassis (see Figure 8.4.2.a.).**

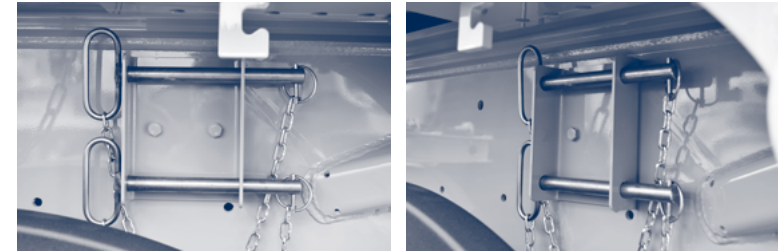

Figure 8.4.2.a. – Position of levers for blocking automatic hinged rear under-run bar

### 8.5. WEIGHING EQUIPMENT

#### Description



Figure 8.5.1.a. – Weighing equipment measuring unit

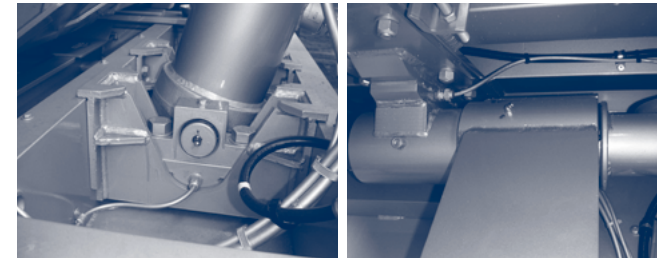

Figure 8.5.1.b. – Measuring cell weighing equipment (resistance strain gauges near tipping cylinder and near rear pin hinges)

Measuring takes place by means of four sensors (resistance strain gauges) placed on the rear pivot (2 hinges) and on the hinge of the tipping cylinder (qty. 2). The values measured by the sensors are processed in the measuring unit. This gives a reading by weight of the load accurate to +/- 100 kg.

The weighing equipment can also generate an alarm signal at a preset weight.

## D. SYSTEM DESCRIPTIONS

### Operation



**The weighing procedure requires slightly tipping of the body. This may not take place during loading. The impact of loading on a tipped body can cause damage. Loading must always take place with the body resting on the chassis (not tipped).**

For the specific operation of the weighing equipment (switching on, setting to zero, setting alarms, etc.) see the appended documentation.

### Weighing procedure

- Activate the weighing equipment
- Tip the body approximately ten centimetres so the whole weight of the body rests on the hinges at the back and the tipping cylinder at the front.
- Read the weight.
- Bring the body back to the horizontal position.
- Switch off the weighing equipment

### 8.6. LANDING LEGS AT THE BACK

#### Description



Figure 8.6.1.a. – Landing legs at the back

The landing legs at the back are provided for extra stability during tipping. If the trailer is fitted with these legs they must always be brought into the supporting position before starting tipping.

#### Operation



- **When landing legs are provided on the trailer at the back they must always be used when tipping.**
- **The disassembly of the landing legs is absolutely forbidden! STAS accepts no responsibility whatsoever if this instruction is not complied with!**
- **As distinct from the landing legs at the front, the landing legs at the back can each be separately operated.**

#### Lowering the landing legs

- Check whether both landing legs can be lowered onto a sufficiently strong surface
- Loosen the lever of one of the landing legs.
- Pull the lever fully out to select the high speed when lowering
- Turn the lever clockwise until the landing legs touch the ground.
- Select low speed by pushing the handle inwards.
- Turn the lever until the trailer is fully supported.
- Bring the lever back to the storage position
- Repeat these steps for the other landing leg
- When the tipping body is resting on the chassis again the landing legs must be put back to the folded up position.
- To do this follow the procedure above in reverse order.

### 8.7. FIRE EXTINGUISHER

The trailer is fitted with a fire extinguisher.

The fire extinguisher is usually located on the landing legs at the front. It may exceptionally be attached somewhere else (e.g. near the tipping cylinder), see Figure 8.7.a.



Figure 8.7.a. – Location of fire extinguisher on the tipper

### 8.8. FLOOR HEATING



Figure 8.8.a. – Floor heating

The body can optionally be provided with floor heating (Langendorf patent). The exhaust gases from the lorry are lead to the floor of the trailer to obtain heating (see Figure 8.8.a.) through a connecting piece. The exhaust gases heat the underfloor because they are guided in the confined space between the profiles of the subfloor of the body. The exhaust gases leave the trailer through holes in the underfloor. At the back of the trailer there are two venturis (one on each side). The wind caused by driving causes negative pressure in these venturis. This negative pressure ensures a draught in the space under the underfloor.



**Do not touch the connecting piece. Danger of burns.**

## D. SYSTEM DESCRIPTIONS

### 9. LIGHTING AND SIGNALISATION

The equipment consists of:

- front position lights with built-in reflectors,
- registration plate light,
- side-marker lights with built-in reflectors,
- end outline marker lights,
- reflectors at the rear of the trailer,
- rear lights consisting of various compartments in which rear light, brake light, reflector, direction indicator, fog light and reversing light have been installed.

The electrical supply is 24V in accordance with the 76/756/EEC regulations.

The connections are:

- ISO 12098 – 15 pin
- ISO 1185 “N” – 7 pin
- ISO 3731 “S” – 7 pin



**Faulty lights should be replaced immediately in order to prevent further damage, to maintain the trailer in accordance with the regulations and to avoid any accidents.**



Figure 9.a. - Lighting connectors

**ISO12098**



ISO1185	
1/31	Weight
2/58L	Position light left
3/L	Direction indicator left
4/54	Brake light
5/R	Direction indicator right
6/58R	Position light right
7/54G	Free
ISO3731	
1/31	Weight
2/58L	Free
3/L	Reversing light
4/54	Free
5/R	Free
6/58R	Free
7	Fog light

ISO12098	
1	Direction indicator left
2	Direction indicator right
3	Fog light
4	Weight
5	Position light left
6	Position light right
7	Brake light
8	Reversing light
9	Free
10	Free
11	Free
12	Free
13	Mass for data line
14	Data line
15	Data line

A detailed overview of the lighting and signaling can be found in the service book.

## D. SYSTEM DESCRIPTIONS

### 10. VARIOUS ACCESSORIES

#### 10.1. TOOL BOX

The tool box is located at the side of the trailer and is used to stock:

- various types of tools,
- fire extinguisher,
- wheel wrench
- ...

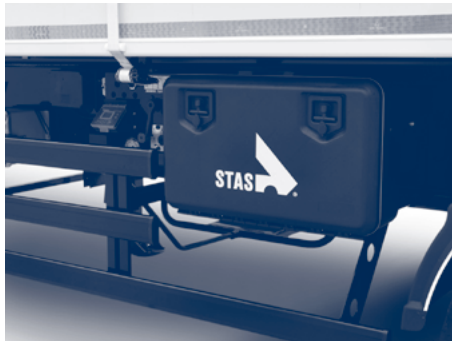

Figure 10.1.a. – Tool box



The weight of the total contents of the tool box may not exceed 25 kg.

Always ensure the tool box is locked in order to prevent theft or accidental opening of the tool box (e.g. during driving).

#### 10.2. RETRACTABLE LADDER FOR ACCESSING LOAD SPACE

The trailer can **optionally** be provided with a retractable ladder at the back that gives the user access to the loading area. This ladder is locked in its retracted position by an elastic strap.



Figure 10.2.a. – Ladder (optional) for access to loading area



When the ladder is being used, ensure it is fully retracted. The ladder should not be used as a support for moving heavy loads into or out of the load space.

During unloading, the ladder should be fully pushed in so as not to obstruct the unloading process and to avoid damaging the ladder.

#### 10.3. SIDE GUARDS

For safety reasons, the side guards serve to protect other road users on both sides from the open space underneath the trailer.

Behind the side guards there are some items of equipment (such as the spare wheel, etc.). The side guards can be folded upwards to reach it.



Figure 10.3.a. – Side guards

In order to raise the side guard, proceed as follows:

- Remove the locking fittings on both sides of the side guard and raise the side guard.



Figure 10.3.b. – Pull out safety pin and folding side guard upwards

- Secure the side guards in the folded up position by sliding the bolt in.



Figure 10.3.c. – Side guards folded up and secured

In order to close the hinged side guard, follow the above procedure in reverse order.



The side guard should always be secured when the trailer is being driven.

Ensure the side guard is correctly secured in position if you need to go underneath it.

## D. SYSTEM DESCRIPTIONS

---

### 10.4. LADDER

The ladder is located on the right-hand side of the trailer at the bottom against the chassis.

It is held in place by a rod through a rung of the ladder. This rod is locked with a locking pin (fixed to a chain).



Figure 10.4.a. - Ladder



Figure 10.4.b. - Locking the ladder



In order to prevent theft it is strongly recommended to use a lock to secure the ladder.

## E. SPECIFIC PROCEDURES

### 1. TRAILER COUPLING AND UNCOUPLING

#### 1.1. COUPLING

##### **Preliminary inspections**

Prior to coupling the trailer to the lorry, it is extremely important that the following checks are carried out:

- the fifth wheel rubbing plate and mounting must be in perfect condition (no tears, deformation or dents),
- the kingpin and kingpin mounting must be in perfect condition,
- a layer of grease must be present on the fifth wheel rubbing plate, the pin and the fifth wheel and these various components should be greased sufficiently,
- there should be no foreign objects (imbedded in the layer of grease) which could obstruct the correct coupling of the lorry and the trailer.

##### **Procedure**

To couple the trailer, proceed as follows:

- Apply the trailer's parking brake (see § D.3.9).
- Check whether the locking of the fifth wheel is open.
- Check whether the rear of the fifth wheel is pointing downwards.
- Check the coupling height (see § D.1) and adjust using the landing legs (see § D.2). If the coupling height is correct, the fifth wheel will lift the trailer during the coupling procedure.
- Ensure the lorry and trailer are correctly aligned before coupling the trailer.
- Slowly reverse the lorry until it locks into a coupled position.
- Check whether the lorry/trailer combination has been coupled correctly by attempting to drive forward slowly whilst the parking brake of the trailer is still on.
- Visually check a correct coupling has been made and that the locking pin of the fifth wheel is in the correct position.
- Connect the electrical lines and the brake lines whilst respecting the colour coding.



- **Once the electrical connections have been made, a visual check of all functions must always be carried out.**
- **Check to ensure all rear floodlights, which could bother traffic coming from behind, are switched off.**
- **If there is any visible corrosion or other faults (e.g. cables without insulation), these must be rectified immediately in order to avoid short-circuiting.**
- **Damage to plugs, switch box, etc. must be repaired as soon as possible.**
- **For safety reasons it is not recommended to drive with coupled hydraulic connections. It is better to connect the hydraulic hose to a dummy coupling on the lorry.**

- Raise the landing legs to their highest position and fasten the lever in the safety hook for the steel type, and position the locking pins for the aluminium type (see § D.2).
- Release trailer parking brake (see § D.3.9).
- Test the ABS system. A warning light on the dashboard of the lorry provides information on the ABS system of the trailer to the operator. If the ABS system is functioning correctly, the ABS light will light up when the ignition is switched on and will go out at a speed of 7 km/hour or after 2 seconds.



##### **Exceptions which do not represent a fault in the ABS system:**

- **Warning light flashes 4 times once the ignition has been switched on: this indicates worn brake pads on the trailer.**
- **Warning light flashes 8 times once the ignition has been switched on: the trailer is due for servicing.**

- The lorry/trailer combination is ready for use.

#### 1.2. UNCOUPLING

To uncouple the trailer, proceed as follows:

- Apply the trailer's parking brake (see § D.3.9).
- Lower the landing legs until they can take the weight which is resting on the lorry. The air suspension of the lorry is used to adjust the aluminium landing legs. See § D.2.
- Disconnect the electrical connections and brake lines.



**Ensure dust, dirt or water cannot get into the couplings and/or air lines. To this end, the covers for the couplings should be placed over the apertures.**

**Close the covers of the electrical connection box securely and store the cables or secure them in a safe place.**

**Always pull the plugs, and never the cables.**

- Open the fifth wheel coupling.
- Carefully drive the lorry away from underneath the trailer.

### 2. TRAILER LOADING AND UNLOADING

#### 2.1. GENERAL SAFETY INSTRUCTIONS CONCERNING LOADING AND UNLOADING



**Check that there are no persons in the trailer before starting loading, activating the tipping system or before closing the door of the trailer. Driving with persons in the trailer is prohibited.**



See Figure 2.1.a.:

- The hydraulic system (e.g. of the lorry) used for tipping must be provided with a safety valve set to the maximum pressure specified on the type plate of the cylinder.
- The stability of the trailer, during driving as well as unloading, is determined to a large extent by the way in which the trailer is loaded. Always ensure the uniform distribution of the load, both longitudinally and laterally.
- Do not tip on an uneven or soft surface.
- Never work under the tipping body without supports under the tipping body.
- It is forbidden to proceed into the working area of the tipper.
- It is forbidden to drive with tipped body.

**When loading and unloading the lorry and trailer must be in line on a flat and stable surface.**



**During loading as well as unloading, the trailer must be coupled to the lorry. Never load or unload near electrical cables or constructions above the trailer.**

## E. SPECIFIC PROCEDURES

SAFE TIPPING

This cylinder is designed as a lifting device only. It must not be used as a structural member or be a subject to side loads and/or abnormal conditions.  
For optimum use of the cylinder and for safety while tipping, following guidelines should be followed.

Oilspecification : ISO VG with viscosity between 75mm<sup>2</sup>/sec. and 16mm<sup>2</sup>/sec.  
Recommended filtration : 25 µm  
Provide the system with a pressure relief valve set to the maximum working pressure as indicated on the identification shield.

STAS

RIGHT

WRONG

**IT IS PROHIBITED TO:**

Figure 2.1.a. – Illustration of a number of general safety instructions concerning loading and unloading

### 2.2. LOADING THE TRAILER

Always first read the general safety instructions on loading and unloading § 2.1.

Loading must always take place with the body resting on the chassis (not tipped).

When loading the lorry and trailer must be in line on a flat and stable surface.

Always check that the tipper is suitable for the load to be transported. This means the type of load, the density of the load (also see § 2.4), and the suitability of the rear doors for unloading the load. Also remember that the tipping angle can vary depending on the load.

In case of doubt do not hesitate to contact STAS nv.

#### Loading bulk goods

For loading the trailer with bulk goods:

- the roof sheet must be open,
- the doors (and grain hatches) must remain closed,
- the loads are loaded into the trailer body from above.

It is not allowed to observe loading from the catwalk at the front of the trailer.

Make sure during loading that you keep a safe distance from the vehicle and the loader. Be alert for objects that can fall from the loader or the vehicle.

Make persons loading the trailer aware of the position of the “roof arches”. These are marked with red arrows on the side of the trailer (see Figure 2.2.2.a.).



Figure 2.2.2.a. – Position of roof arches in the tipper (marked with red arrow)

#### Loading pallets (only applies to type OP tipper)

Pallets can be loaded by customary loading techniques.  
Access to the trailer is through the rear doors

In principle, forklift trucks can drive over all floor constructions. Please contact STAS for information regarding permissible loads.

## E. SPECIFIC PROCEDURES

### 2.3. UNLOADING THE TRAILER

#### General

#### Safety measures



Always first read the general safety instructions on loading and unloading § 2.1. To prevent damage to the roof sheet (e.g. by vacuum extraction when tipping bulk goods) this must always be open when unloading the trailer.

It is forbidden to tip the vehicle:

- if it is uncoupled
- if the lorry and trailer are not in line
- on an uneven surface
- on an unstable surface
- with high wind speeds and/or wind gusts (more than 60 km/hour)
- square to the wind direction

Adhesive loads or loads with varying densities can become loose unevenly during tipping. This can lead to instability.

With the threatened instability of the trailer during the tipping IMMEDIATELY allow the tipping body to lower and rest on the chassis. One can then examine the cause of the instability.

It is forbidden to leave hydraulic connections (or the electrical power cable of the separate electrohydraulic tipping set) connected on the trailer after the completion of the loading. This is to avoid tipping being accidentally activated. If a supervisor assists with unloading the trailer, he must be familiar with operation of the tipper.

#### Tipping with or without air in the bags

In the procedures concerning the unloading (tipping) of bulk goods it is not specified if this must take place with or without air in the air bags. This is because tipping with or without air in the air bags depends on the situation and must be assessed by the driver.

The advantages and disadvantages of tipping with or without air in the air bags are briefly mentioned below. It is up to the driver to decide whether to tip with or without air in the air bags.

#### - Tipping without air in the air bags:

##### ADVANTAGES:

- Greater lateral stability of suspension because the influence of the damping of the suspension is switched off.

- The vehicle bounces less with the sudden displacement of the load

##### DISADVANTAGES:

- All the load is exerted on the rear axle, suspension and tyres that are more heavily loaded.
- Lateral stability must be achieved on one axle.
- The greater lateral forces distort the rear tyres more.
- Greater load on the ground because all weight comes on a reduced "footprint" of the tyres. Can be particularly important on soft surface.

#### - Tipping with air in the air bags:

##### ADVANTAGES:

- Load and lateral stability are ensured by all axles.
- No repeatedly overloading of axles, suspension and tyres.
- Less great load on the ground with a larger "footprint". Important on soft surfaces.
- Less deformation of the tyres.

##### DISADVANTAGES:

- Less lateral stability due to the influence of the suspension damping.
- Risk of the vehicle bouncing up with a sudden load displacement.

#### Tipping a trailer not provided with separate electrohydraulic unit

Here there is no separate electrohydraulic unit provided on the trailer. Tipping takes place by means of a hydraulic set assembled on the lorry and connected to the tipping cylinder.

- Apply the handbrake.



Check that there is sufficient oil in the tank of the hydraulic set on the lorry (oil level approximately 5 cm below the filler opening with withdrawn cylinder).

Make sure the lorry's hydraulic system is adapted to the cylinder assembled on the trailer. The working pressure may not exceed the pressure mentioned on the type plate of the cylinder and on the pictogram near the hydraulic connection cylinder.

During tipping stay in the cab until the tipping body has been tipped empty.

- Make sure the lorry and trailer are in line and on a flat and stable surface.
- If the trailer is fitted with landing legs at the back these must be lowered. See § 8.6.
- If the trailer is fitted with a hinged rear under-run bar, this may be hinged. See § 8.4.
- Open the roof sheet. For the specific procedure for the opening of the specific type of roof sheet see § 7.2, § 7.3 or § 7.4.
- Connect the hydraulic circuit of the lorry to the cylinder.
- One hydraulic hose is connected with a single hydraulic circuit. A double hydraulic circuit has a second hose (from the pressure relief valve) that is connected back to the hydraulic tank.
- Make sure there is no one in the danger zone (X = length of the body).



Figure 2.3.2.a. - Hydraulic connection single-line system (left), two-line system (right)

- Start engine, check if there is sufficient air pressure.

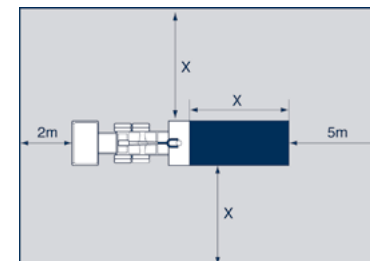

Figure 2.3.2.b. - Danger zone when tipping

#### Unloading (tipping) bulk goods



## E. SPECIFIC PROCEDURES



For information an example is given here of a control panel and operating procedure for this type of PTO.



Figure 2.3.2.c. - PTO operating panel

- Press pedal and wait 4 seconds.
- Press blocking and switch PTO to "in".
- Allow pedal to rise.
- Move tipping handle to "raise" and secure.
- Gradually raise body by changing the engine speed (number of revolutions never higher than 1500 rpm)
- Prevent the tipped material accumulating and moving against the tailboard by driving forward EXTREMELY SLOWLY AND NEVER MORE THAN A METRE AT A TIME.
- When the tipping body has reached the required tipping angle release the lever and allow to return to "hold".
- Allow the tipping body to lower by GRADUALLY moving the tipping lever from "hold" to "lower". With types without automatic PTO switching off the PTO must first be switched off.
- Control the lowering speed of the body by moving the lever to "hold" to slow the body down or to "lower" to increase the lowering speed.
- Bring the lever back to "hold" as soon as the tipping body is fully resting on the chassis.
- Disconnect the hydraulic connections.
- Lock the doors. For the specific procedure see the system description in § D.6.
- Close roof sheet. For the specific procedure for the closing of the specific type of roof sheet see § D.7.2, § D.7.3 or § D.7.4.
- If the trailer is fitted with landing legs at the back these must be raised. See § D.8.6.
- Before driving away check that the tipping has not caused any damage (e.g. to the signs, mud flaps, mud-guards, rear under-run bars, etc.).



- When coupling and uncoupling the hydraulic connections, a small quantity of oil may leak out of the coupling(s).
- The use of antistatic oil-absorbing cloths is recommended.
- These cloths are hydrophobe : they reject water and absorb only oil and liquids on oil base (not supplied by STAS).

Additional documentation about these cloths – see for example [www.seton.be](http://www.seton.be)

### Tipping of a trailer provided with separate electrohydraulic unit

Here there is a separate electrohydraulic unit provided on the trailer. The lorry provides the supply voltage for the electrohydraulic unit through two adapted electrical cables (2 x 35 mm<sup>2</sup>).



Check that there is sufficient oil in the tank of the hydraulic set on the trailer (oil level approximately 5 cm below the filler opening with withdrawn cylinder).

When tipping the load can become stuck at the tailboard. This can be prevented driving forward EXTREMELY SLOWLY, AND NO MORE THAN A METRE AT A TIME.

- Apply the handbrake.
- Make sure the lorry and trailer are in line and on a flat and stable surface.
- If the trailer is fitted with landing legs at the back these must be lowered. See § D.8.6.
- Open the roof sheet. For the specific procedure for the opening of the specific type of roof sheet see § D.7.2, § D.7.3 or § D.7.4.
- Check that there is no one in the danger zone. (X = length body)

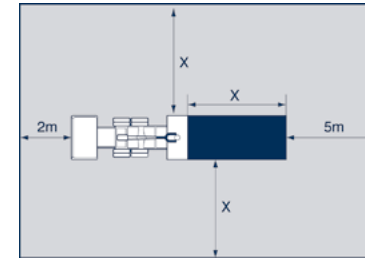

Figure 2.3.2.d. - Danger zone when tipping

- Unlock the doors. For the specific procedure see the system description in § D.6.
- Connect the electrical cables of the electrohydraulic unit to the lorry.
- Start the lorry (to prevent the battery from running down due to use of the hydraulic set).
- Open the hydraulic set's protective cover.
- Take the operating button and proceed outside the danger zone.
- Unlock the emergency stop (3). One can raise the body with the button (2). When one releases the button (2) the cylinder remains in position. Button (1) is to lower the body. In an emergency the power can be interrupted by pressing the emergency stop (3). In the case of an electrical defect with extended cylinder this can be brought in by loosening the emergency screw (4) on the valve block.

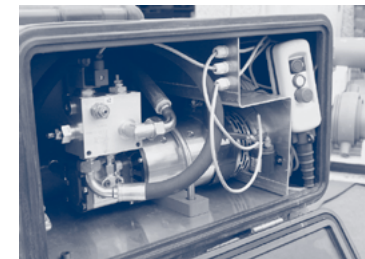

Figure 2.3.2.e. - Electrohydraulic unit with operating button

- Gradually raise the body.
- Prevent the tipped material accumulating and moving against the tailboard by driving forward EXTREMELY SLOWLY AND NEVER MORE THAN A METRE AT A TIME.
- Lower the tipping body by operating the button (3).
- As soon as the tipping body is resting on the chassis again press the emergency stop and put away the operating button.
- Disconnect the electrical connections between the lorry and electrohydraulic unit.
- Lock the doors before driving away. For the specific procedure see the system description in § D.6.
- Close roof sheet. For the specific procedure for the closing of the specific type of roof sheet see § D.7.2., § D.7.3 or § D.7.4.
- If the trailer is fitted with landing legs at the back these must be raised. See § 8.6.
- Before driving away check that the tipping has not caused any damage (e.g. to the signs, mud flaps, mud-guards, rear under-run bars, etc.).

## E. SPECIFIC PROCEDURES

### Unloading pallets (only applies to tipper type OP)

Pallets are unloaded with the tipping body resting on the chassis.  
Access to the trailer is through the rear doors



In principle, forklift trucks can drive over all floor constructions. Please contact STAS nv for information regarding permissible loads.

### 2.4. WEIGHTS AND TIPPING ANGLES FOR VARIOUS PRODUCTS

#### Tipping angles for various products

PRODUCT		TIPPING ANGLE (IN DEGREES)
Soil	loose	28
	solid	50
Asphalt		45
Ashes	dry	33
	moist	36
	wet	30
Concrete		30
Coke		23
Ore	dry	30
	just reclaimed	37
Grit		40
Gravel		40
Clay		45
Debris		45
Slag and clay		30
Slag	dry	33
	moist	34
	wet	31
Stones	chunks	30
	broken	27
	crushed	30
Coal	hard	24
	soft	30
Stones		40
Refuse		30
Sand and crushed stones		27
Sand	dry	35
	moist	40

Source: this information is taken from the "Essential tipper handbook" by Kerril B. Spencer (published April 1994)

### 3. VENTING THE HYDRAULIC CYLINDER

When the cylinder jolts outwards this can be a result of air in the cylinder.  
Depending on the type of hydraulic cylinder a different procedure is used to vent it.



Before venting always check there is sufficient oil in the tank on the trailer or lorry.  
Air in the hydraulic circuit is often caused by tipping with insufficient oil in the tank.

#### 3.1. HYDRAULIC CYLINDER OF THE MAKE HYVA

Cylinders of the make Hyva have automatic air venting. The air disappears from the cylinder after a number of times of tipping. In any case check there is sufficient oil in the hydraulic tank.

#### 3.2. HYDRAULIC CYLINDER OF THE MAKE EDBRO

This cylinder has a venting bolt.



Make sure that no one is located near the tipping body.  
Remember that during venting the tipping body will lower.

- Raise the tipping body 20 centimetres using the cylinder (see § 2.3.2 for the procedure).
- Remove the plastic protective cover.
- Slowly turn the venting bolt open so the air can escape from the system. Caution: the tipping body will slowly lower and force the air out of the system.

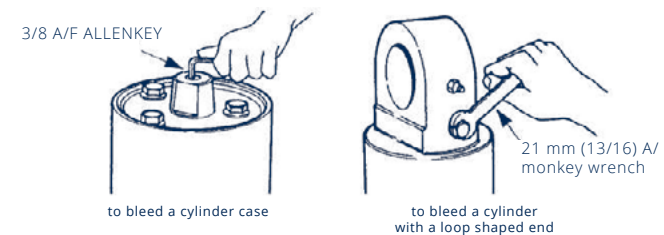

Figure 3.2.a. - Cylinder venting

- When only oil comes out of the opening tighten the bolt.
- Allow the tipping body to fully lower, check the oil level and top up if necessary.
- If the cylinder still jolts: carry out the procedure again.

## F. PREVENTIVE MAINTENANCE



- Ensure that no one is able to activate the tipping mechanism or the hydraulic rear door when work is being carried out in the trailer.
- It is recommended that a second person supervises whilst work is being carried out in the trailer.

Preventive maintenance on the trailer may be divided into the following sections:

- Mechanical maintenance of the trailer (see § 1)
- Maintenance of the bodywork of the trailer (see § 2)
- Maintenance of the hydraulic tipping cylinder (see § 3)

### 1. MECHANICAL MAINTENANCE

#### 1.1. VISUAL CHECKS

A general visual inspection of the trailer should be carried out at regular intervals and any damaged or faulty components must be replaced or repaired immediately.

#### 1.2. TYRES

Visually check the tyre pressures before each trip. Tyre pressures should be measured weekly and adjusted if required. The table below shows the recommended tyre pressure and rims for the most common tyre sizes. If the trailer is fitted with a different tyre size, the correct tyre pressure may be obtained from the manufacturer.

Tyre size	Rim width (advice)	Recommended tyre pressure (bar)
425/55 R19.5	13.00 x 19.5	9
445/45 R19.5	14.00 x 19.5	9
445/65 R19.5	14.00 x 19.5	8.5
11 x 22.5	7.50 x 22.5	8
12 x 22.5	8.25 x 22.5	8.5
13 x 22.5	9.00 x 22.5	8.5
365/80 R20	10.00 x 20	9
385/65 R22.5	11.75 x 22.5	9
425/65 R22.5	13.00 x 22.5	8.5
445/65 R22.5	14.00 x 22.5	9

Check whether the tyres of the trailer still have the regulatory tread on a regular basis. Replace the tyres in good time.



Inspecting the tyres is extremely important for your safety and the safety of others.

### 1.3. TIGHTENING TORQUES FOR BOLTS

All bolts and nuts should be inspected on a monthly basis. Particular attention should be paid to the bolts and nuts in the tipping system, the fifth wheel rubbing plate and the axle attachment to the chassis.

The following table indicates the tightening torques for normal construction bolts according to class 8.8 and class 10.9 (as per DIN ISO 898 - Part 1).

Size	Tightening torque (Nm)		Size	Tightening torque (Nm)	
	Class 8.8	Class 10.9		Class 8.8	Class 10.9
M5	5.5	8.1	M20	425	610
M6	9.6	14	M20x1.5	475	680
M8	23	34	M22	580	820
M8x1	25	37	M22x1.5	630	900
M10	46	67	M24	730	1050
M10x1.25	49	71	M24x2	800	1150
M12	79	115	M27	1100	1550
M12x1.25	83	120	M27x2	1150	1650
M14	125	185	M30	1400	2000
M14x1.5	135	200	M30x2	1500	2150
M16	195	295	M36	2450	3500
M16x1.5	210	310	M36x2	2650	3780
M18	300	430	M42	3930	5600
M18x1.5	340	485	M42x2	4280	6050

The tightening torques mentioned apply to M16x1.5 for bolts with galvanised surfaces and a surface roughness  $\mu=0.125$ . With larger diameters the surface roughness is  $\mu=0.140$ .



The previously stated tightening torques do NOT apply:

- to wheel nuts,
- when lubricants such as MOS2 are used.

Please also refer to the additional documentation supplied with the trailer for tightening torques for hinges of the tipping system, axles, brakes and suspension.

## F. PREVENTIVE MAINTENANCE

### 2. MAINTENANCE SCHEDULE TRAILER BODYWORK

Properly maintained bodywork will prolong the life of the trailer. The trailer should be washed using a suitable detergent (car shampoo) and sufficient water.



**In order to avoid problems with the paint, it is advisable not to clean the trailer for the first 4 weeks using a high pressure cleaner and/or detergent. Refer to the sticker on the trailer.**

**In order to avoid paint damage, the affixed advertisements and stickers should not be removed.**

Instructions for cleaning with high pressure cleaners:

- Use cold water for the first 3 months, with a low dose of neutral detergent if necessary. Working pressure 40-60 bar.
- After 3 months, warm water may be used with a dose of slightly alkaline cleaning material. Temperature 40-60°C. Working pressure 60-100 bar.
- Spraying distance at least 30 cm.
- Do not keep the jet pipe still but move it continuously at an angle of approx. 45° over the paintwork.



**Use of a higher temperature or pressure, a smaller spraying distance and (or) aggressive chemicals cause loss of adhesive strength and gloss of the paint.**

### 3. MAINTENANCE SCHEDULE TIPPING MECHANISM



**Never carry out maintenance activities on the hydraulic installations while they are under pressure (e.g. during tipping).**

**Never allow the tipping cylinder to be extended for more than 30 minutes in a humid atmosphere.**

**For environmental reasons the filling of hydraulic oil must take place at a workplace for this purpose.**

FREQUENCY	ACTION
Daily	Check oil level: The oil level must be 5 cm below the filler opening with withdrawn cylinder. If this is not the case, filling must take place with the specified oil.
Daily	Check the hydraulic system for defects, leaks or damage
Monthly	Check the bolts of the tipper shaft locking (see Figure 3.a.). Check that the bolts have not become loose or broken.
2-monthly	Lubricate of the tipping mechanism (see § 6)
Annually	Replace the hydraulic oil. Clean the oil tank. CAUTION: never clean the oil tank with water.



Figure 3.a. – Bolts for tipping shaft locking

To prevent damage to the hydraulic system an oil with a viscosity range of 75 mm<sup>2</sup>/sec to 16 mm<sup>2</sup>/sec is specified.

Note: the temperatures refer to the oil temperature, and not the outside temperature.

ISO VG class	Minimum oil temperature at start-up viscosity 400 mm <sup>2</sup> /sec	Minimum oil temperature with a viscosity of 75 mm <sup>2</sup> /sec	Maximum oil temperature with a viscosity of 16 mm <sup>2</sup> /sec	Viscosity index
15	-18 °C	5 °C	38 °C	80
22	-10 °C	16 °C	48 °C	100
32	0 °C	23 °C	58 °C	100
46	+5 °C	30 °C	65 °C (*)	100
68	+10 °C	38 °C	65 °C (*)	100

(\*) It is recommended to use an oil cooler with oil temperatures higher than 65 °C

If the hydraulic system is used in extremely low temperatures (- 30 °C) it is advisable to use an oil that remains sufficiently fluid in such conditions. (ATF oil) If the minimum active viscosity is not reached the oil must be preheated.

The values mentioned in the table are to the best of our knowledge from the information we currently possess.

### 4. MAINTENANCE SCHEDULE ROOF SHEET, TYPE "CRAMARO"

The following checks must periodically be made

- Check the tension of the cables of the roof sheet. Check they do not slip on the cable pulleys. Also check for damage and wear
- Check if there is no damage to the upper part of the tipping body (where the roof sheet moves).
- Check all parts of the roof sheet for damage and wear (side hooks, fabric, etc.).
- Check the electrical connections (earth cable, battery connector) for damage. Keep the contacts clean.
- Wash the roof sheet now and again to remove soiling.

### 5. MAINTENANCE SCHEDULE HINGED REAR UNDER-RUN BAR (OPTION)

FREQUENCY	ACTION
Weekly	Check cable
Monthly	Lubricate the hinges
Two-yearly or after 6,000 movements	Replace the auxiliary springs that automatically bring the rear under-run bar to its lower position. Replace the cable

## F. PREVENTIVE MAINTENANCE

---

### 6. LUBRICATION POINTS

Lubrication takes place with universal grease



Figure 6.a. - Lubrication of cylinder



Figure 6.b. - Lubricate the clamping hoods of the top hinged door and universal door



Figure 6.c. - Lubricate tipper turning points

### 7. WHEELS

The members of EUWA (Association of European wheel manufacturers) would like to inform you about a potential technical issue regarding steel and aluminum wheels for commercial vehicles.

In the European commercial vehicle market a trend to more and more weight optimized hub designs can be noticed. The weight optimisation is often created by using a "star shape" for the outline of the hub.

The definition of the truck wheel attachments, i.e. in the ISO 4107 or DIN 74361-3 are only defining the diameter of the wheel support (outer diameter of the hub), but it is not clearly defined if the outline of the hub must be circular. The definition of other shapes is not explicitly prohibited.

In order to maximize safety, EUWA strictly recommends for the vehicles equipped with non-circular hubs in the field, that the wheels used on such hubs have to be checked towards cracks on the inner and outer attachment face each 50.000 km. In case of crack detection the wheels have to be replaced immediately! Also in such cases the hubs should be checked with regard to wear out and cracks and if necessary the hubs should be replaced.

## G. TROUBLESHOOTING

### 1. MOST COMMON CAUSES OF PROBLEMS WITH THE TIPPING CYLINDER

PHENOMENON	POSSIBLE CAUSE	SOLUTION
Body does not move upwards	Defect on the lorry	Check that everything in the lorry is being operated correctly, if there is sufficient pneumatic pressure, etc.
	Hydraulic pump supplies no oil	Disassemble the hydraulic compressed air hose and check that oil circulates
	Too little oil in the tank	Top up the oil in the tank to approximately 5 cm below the filler cap
	Kinks in oil lines	Make sure there are no kinks in the oil lines
	Poorly screwed on quick-release coupling	Correctly screw on quick-release coupling.
The body does not tip evenly	Defective quick-release coupling	Check and/or replace quick-release coupling.
	There is air in the hydraulic system	Vent: see § E.3 – Venting the hydraulic cylinder Check the oil level in the tank
The body does not fully tip	The hydraulic pump works intermittently	Replace the pump
	Insufficient oil in hydraulic tank	Check the oil level and top up if required.
The body will not lower	Overloading or unevenly distributed load. The pressure relief valve has opened or the pump is not powerful enough to tip	Evenly distribute the load or remove a part of the load in another way
	With an EDBRO cylinder:	Increase engine speed until the pressure relief valve opens (screeching noise). Allow the engine to run for 5 seconds then allow the body to lower
The body does not remain in the tipped position.	With an EDBRO cylinder:	Increase engine speed until the pressure relief valve opens (screeching noise). Allow the engine to run for 5 seconds then allow the body to lower
	Defective pump	Vervang pomp
Cylinder tips too slowly	Viscosity of the oil too high (unsuitable oil at a "low" temperature)	Use the right hydraulic oil.
	Low oil level	Check the oil level and top up if required
Excessive noise	Obstructions and leaks	Check lines for kinks and leaks.

### 2. MOST COMMON CAUSES OF PROBLEM WITH THE ROOF SHEET, TYPE "CRAMARO"

PHENOMENON	POSSIBLE CAUSE	SOLUTION
When operating the selector switch the roof sheet does not move and the indicator light is not on.	Emergency stop pressed.	Reset the emergency button with the key.
	Fuse (80A) blown.	Check fusing and replace if necessary.
	Interrupted power or switched off motor.	Check the electrical installation. Check that there are no broken or disconnected cables.
Slow movement of the roof sheet.	Mechanical problem.	Check whether the rear bearings or discs are running smoothly or are blocked. Replace these components if necessary.
	Deformed roofing sheet arches.	Check whether the roofing sheet arches are distorted and correct if necessary.
	Metal tensioning cables too tight.	Loosen the metal tensioning cables with the tensioning device.
	Metal tensioning cables slip over the discs.	Check whether the discs and tensioning cables are lubricated. Clean if necessary.

### 3. MOST COMMON CAUSES OF PROBLEMS WITH THE "BODYGUARD"

PHENOMENON	POSSIBLE CAUSE	SOLUTION
Ignition on, tipping body resting on the chassis, control light flashes	Soiled proximity switch	Clean proximity switch
	Cables damaged	Check cabling, and replace cables if necessary
	Damaged proximity switch	Replace the proximity switch if necessary, then try to establish the cause of the damage.
The warning system does not work when the ignition is switched on.	Light broken	Replace light
	Cables damaged	Check cabling, and replace cables if necessary.
	No power on the bodyguard	Investigate the cause of the absence of power. Cable breakage, blown safety fuse, etc.

## G. TROUBLESHOOTING

### 4. WABCO DIAGNOSES

#### 4.1. THROUGH SMARTBOARD

<b>Component: TEBS D</b>		093	Freely configurable function 5	133	Output ABS active signal
007	Trailer modulator	094	Freely configurable function 4	134	Road Finisher Brake
010	EBS (ABS) Relay Valve	095	Freely configurable function 3	135 / 136	Not used
058	Trailer modulator	096	Freely configurable function 2	137	Speed switch 2 (ISS 2)
059	Trailer modulator	097	Freely configurable function 1	138	Speed switch 1 (ISS 1)
061	EBS Relay Valve	100	GIO-Freely configurable analogue function	139	Valve residual pressure maintenance for manoeuvring aid
062	EBS Relay Valve / Pressure sensor	101	GIO-Freely configurable digital function	140	Valve residual pressure maintenance for traction help
081	Pneumatic control line	102	Slot GIO 5	141	Lifting axle valve 2
083	Supply pressure sensor	103	Slot GIO 4	142	Lifting axle valve 1
084...086	Electrical switching output	104	Slot GIO 3	143	Pneumatic control line
221	Trailer modulator/ Sensor power supply 24V	105	Slot GIO 2	144	Supply pressure sensor
232	Trailer modulator/ Sensor power supply 5V	106	Slot GIO 1	145	External ELM
246	EBS-Trailer brake valve / Switch	107	Slot GIO 6	146	External ECAS
<b>Component: TEBS E (TEBS D/E)</b>		108	Slot GIO 7	148	Internal ECAS / Calibration
001	Wheel sensor a (TEBS D/E)	109	ABS sensor / Memory bit	156	J2497
002	Wheel sensor b (TEBS D/E)	110	Slot subsystems	157	Switch normal level 2
003	Wheel sensor c (TEBS D/E)	111	Button relaxation function	158	Switch up
004	Wheel sensor d (TEBS D/E)	112	Switch "Automatic lowering of the lifting axle"	159	Switch down
005	Wheel sensor e (TEBS D/E)	113	SmartBoard	160	Brake release function
006	Wheel sensor f (TEBS D/E)	114	Diagnostics power supply	163	Axle load calibration
007	EBS (ABS) relay valve / Solenoid valve control (TEBS E)	115	Telematics	164 / 165	Not used
009	Trailer modulator / Solenoid valve control (TEBS E)	116	IVTM	167	Output steering axle lock
010	Trailer modulator / Solenoid control	117	ECAS Remote-Control Unit / Box	168	Switch output steering axle lock
058	EBS Relay Valve / Redundancy	118	Axle load sensor external (Axle c-d)	169	not used
059	EBS Relay Valve / Pressure sensor	119	Axle load sensor external (axle e-f)	170	Output tilt warning
061	Trailer modulator / Redundancy	120	Distance sensor axle load (axle c-d)	220	Data link towing vehicle / trailer (TEBS D/E)
062	Trailer modulator / Pressure sensors	121	Distance sensor axle load (axle e-f)	250	J1708
069	Axle Load Sensor Internal (TEBS D/E)	122	Freely programmable function 3	251	Power Supply (TEBS D/E)
075	Wear sensor (TEBS D/E)	123	VFreely programmable function 2	253	Parameter settings (TEBS D/E)
076	Failure of target value selection / redundant braking (TEBS D/E)	124	Freely programmable function 1	254	Trailer modulator (TEBS D/E)
077	Desired pressure sensor internal (TEBS D/E)	125	Switch unloading level	<b>Component IVTM</b>	
078	Desired pressure sensor external (TEBS D/E)	126	Output speed signal	639	CAN (Short circuit / bus off)
088	Lateral acceleration sensor (TEBS D/E)	127	Distance sensor 2 (axle e-f)	927	Warning lamp 2 (optional / pin 4)
089	Proximity switch	128	Distance sensor 1 (axle c-d)	928	Warning lamp 1 (standard /pin 2)
090	Freely configurable function 8	129	ECAS valve block	929	Tyre data cannot be analysed
091	Freely configurable function 7	130	Output continuous positive voltage 2	1121	Data on the CAN data bus
092	Freely configurable function 6	131	Output continuous positive voltage 1	3011... 3054	Pressure in tyre
		132	Output RSS active signal	3111... 3154	Leaking in tyres and valves
				3410... 3500	Tyre pressure deviation

## G. TROUBLESHOOTING

---

Type of fault	
00	Value too high
01	Value too low
02	Data is irregular or incorrect
03	Overvoltage / Short circuit to 24V
04	Undervoltage / Short circuit to ground
05	Supply cable interruption
06	Current too high or circuit grounded
07	Air gap too big
08	Slip
09	Signal failure
10	Jump up / Jump down
11 / 12	See failure note
13	Characteristics error
14	Special faults / See fault info
15	See failure note

### 4.2. VIA INTERFACE AND PC WITH VOLTAGE SUPPLY ISO7638

By using the Interface and a PC with correct software, the user can call for the system information and read and update the memory diagnoses.



## H. TECHNICAL SPECIFICATIONS

### 1. TRAILER - MECHANICAL

#### 1.1. KINGPIN AND FIFTH WHEEL RUBBING PLATE

A GF662/102/601 type kingpin is used on a steel fifth wheel rubbing plate.

The kingpin can be removed on the underside out of its socket by unscrewing the eight bolts M14x1.5. These bolts must be tightened with a tightening torque of 180 Nm.

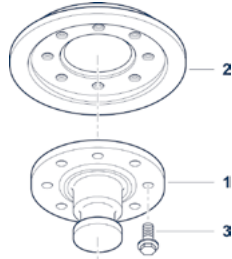

Figure 1.1.a. – Kingpin (1), socket (2) and retaining bolt (3)

A JOST KZ1312 type kingpin is used on an aluminium fifth wheel rubbing plate. This kingpin is screwed onto the aluminium fifth wheel rubbing plate with eight M14 or M14x1.5 bolts with a torque of 130 Nm.

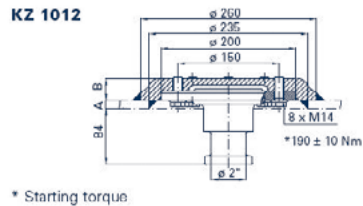

Figure 1.1.b. – Kingpin with aluminium fifth wheel rubbing plate



All kingpins used comply with EC directive 94/20 of 30 May 1994. It is desirable to check the fastening and wear of the kingpin once a week.

#### Instructions relating to the assessment of worn and/or deformed 2" trailer couplings

				Minimum pin diameter in mm	Original pin diameter in mm
WEAR	I	Pin surface worn locally and evenly showing negligible grooves	Height measuring surface max. 4 mm	d1 = 70 d2 = 49	d1 = 73 ± 0.1 d2 = 50.8 ± 0.1
	II	Pin surface worn locally and showing several scores and/or holes		d1 = 71 d2 = 49.5	d1 = 73 ± 0.1 d2 = 50.8 ± 0.1

Figure 1.1.c. – Measurement kingpin wear

#### 1.2. ALUMINIUM LANDING LEGS

	Maximum load
Trailer with 2 aluminium landing legs	10700kg
Trailer with 1 aluminium landing leg	Empty trailer

#### 1.3. LANDING LEGS "STEEL TYPE" (AT THE FRONT AND AT THE BACK)

Lifting capacity	24 tons
Static loading capacity	50 tons for landing legs with swinging leg
	36 tons for landing legs fitted with wheels
Force to be applied to handle for a load of 16 tons	210 N

#### 2. TIPPING SYSTEM

The tipping system is selected depending on the intended use of the trailer. For further information contact STAS nv.

## I. COMMENTS

---

A series of 20 horizontal dotted lines for writing comments.

## I. COMMENTS

---

.....

.....

.....

.....

.....

.....

.....

.....

.....

.....

.....

.....

.....

.....

.....

.....

.....

.....

.....

.....

.....

.....

## I. COMMENTS

---

.....

.....

.....

.....

.....

.....

.....

.....

.....

.....

.....

.....

.....

.....

.....

.....

.....

.....

.....

.....

.....

.....

.....

.....



Discover our stars on  
[www.stas.be](http://www.stas.be)



Dive into the world of the dealers,  
clients and drivers of STAS on  
[www.ilovemystas.com](http://www.ilovemystas.com)